

Self-priming magnetic drive pumps

Chemically resistant self-priming magnetic drive pumps
which can tolerate abnormal operation



Self-priming magnetic drive pumps

The SMX-F is a horizontal self-priming magnetic drive pump made from fluoro-resin.
Our original self-radiation structure enhances resistance to abnormal operations.



Chemically resistant self-priming magnetic drive pumps which can tolerate abnormal operation



The SMX-F is a horizontal self-priming magnetic drive pump made from fluoro-resin. Our original self-radiation structure enhances resistance to dry running, cavitation, and closed-discharge operation. In addition, the use of standard motors extends the range of application.



SMX-F441

SMX-F221

Excellent corrosion resistance

The casings, impeller assembly and magnet capsule are made of fluororesin (CFRETFE). Other wet-end parts are made of highly corrosion resistant materials such as carbon, ceramic and the like. The pumps can handle almost type of chemicals including strong acid/alkali.

Expanded versatility

The SMX-F has a modular structure to handle liquids with high specific gravities. Use of standard motors extends the range of liquid application.

Easy maintenance

The pump wet end can be removed from the motor as a complete assembly without dismantling, thanks to an additional rear casing support. The pump wet end comprises the minimum number of parts for easy maintenance.

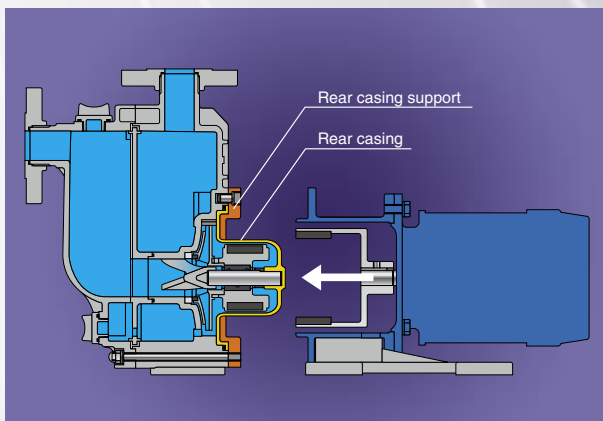

Enhanced durability under abnormal operation

Our original self-radiation structure (Patented) efficiently disperses bearing friction heat to protect the pump under abnormal operating conditions. In addition, our non-contact structure prevents contact between rear thrust face and bearing, to eliminate heat buildup during dry running.

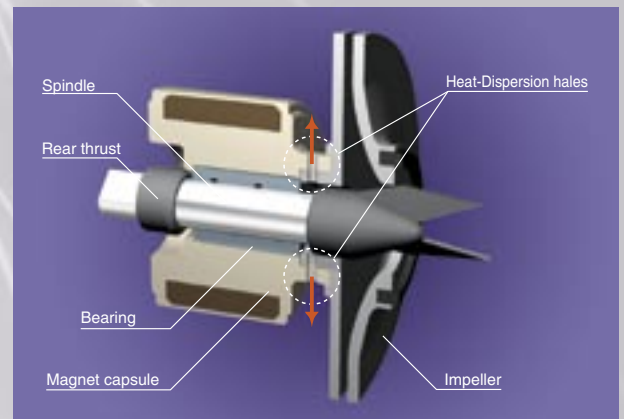

Fast self-priming

The SMX-F requires no external self-priming chambers or valves. The gas-liquid separation design ensures fast self-priming. An exceptional self-priming duration of up to 4m in only 90 seconds is now possible.

Rear casing support

The pump wet end is easily removed from the motor by removal of 4 mounting bolts on the motor bracket. The rear casing support performs easy maintenance and draining of any residual liquid at other place.

Examples of application

Pumping up from underground tank

- Underground tank at chemical plant.
- Underground tank or pit of waste plant.

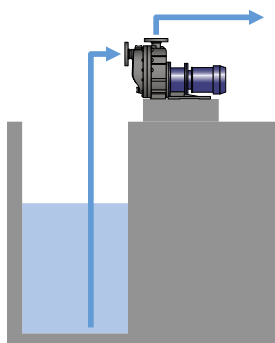

Pumping up and out from top of tank and tanker truck

- Transferring etching and plating chemical from chemical bath.
- Sucking up chemical from truck.
- Pumping up from top of tank.

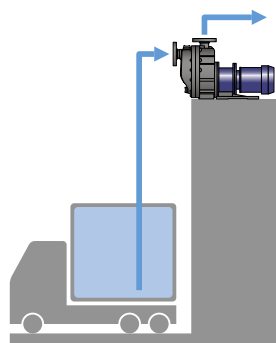

Transferring chemical from tank to tank and tanker truck

- Transferring from main tank to daily tank.
- Refilling chemical from drum to tank.

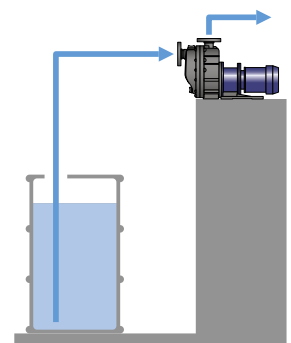
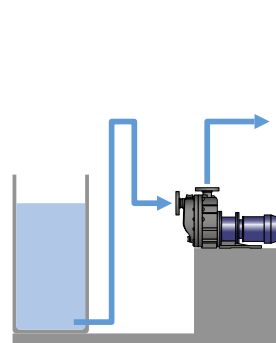

Reliability and performance are enhanced by our unique design

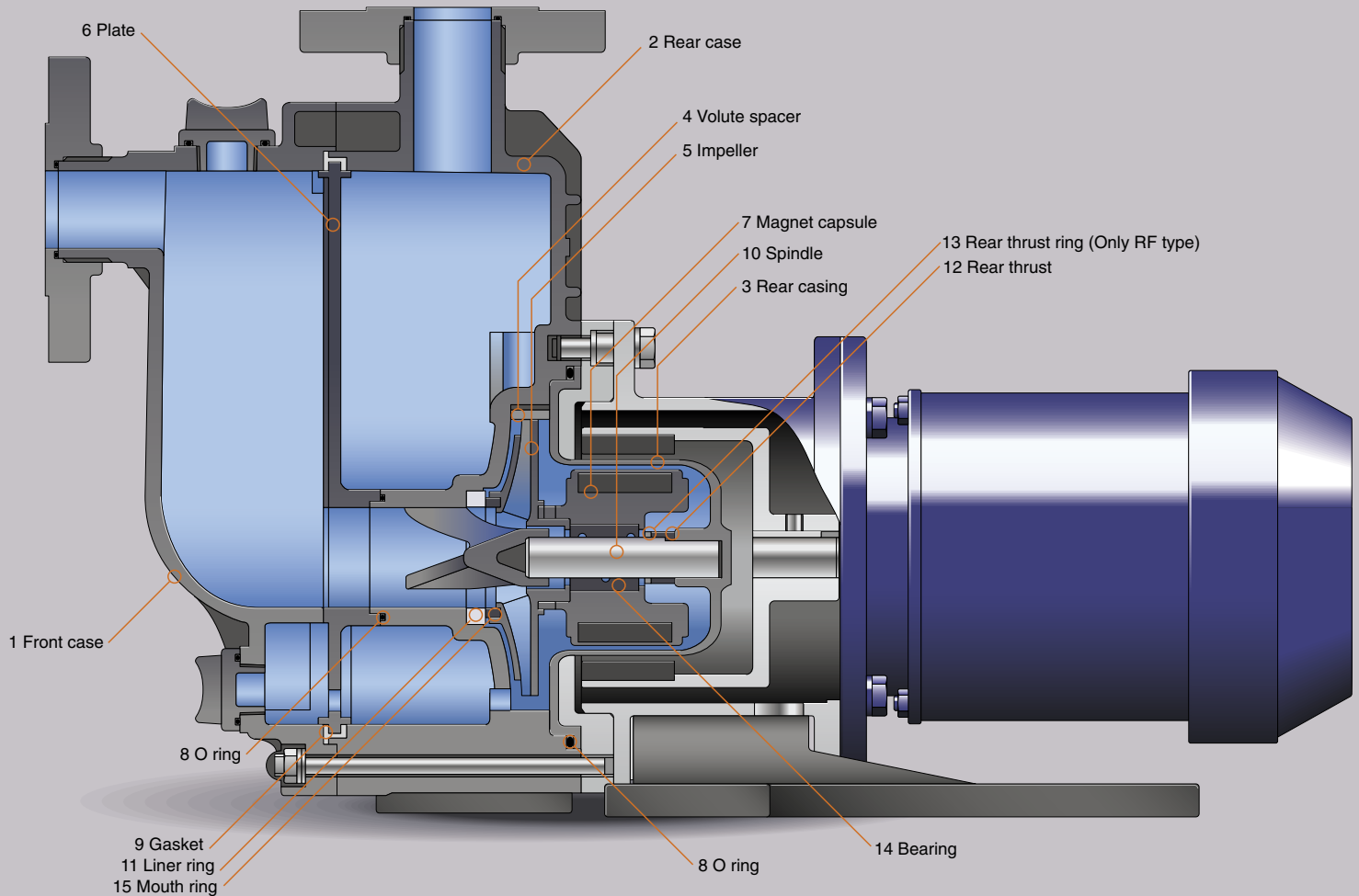

Wet-end materials

Name of part	Model	CF	RF	KK
1 Front case		CFRETFE		
2 Rear case				
3 Rear casing				
4 Volute spacer				
5 Impeller				
6 Plate				
7 Magnet capsule				
8 O ring		FKM/EPDM		
9 Gasket		FKM/EPDM		
10 Spindle		High purity alumina ceramic		SiC
11 Liner ring		CFRETFE		
12 Rear thrust		CFRETFE		
13 Rear thrust ring	Note	—	High purity alumina ceramic	—
14 Bearing		High density carbon	PTFE (With filler)	SiC
15 Mouth ring		PTFE (With filler)		

Note: Exclusive for RF type



Principles of Self-Priming:

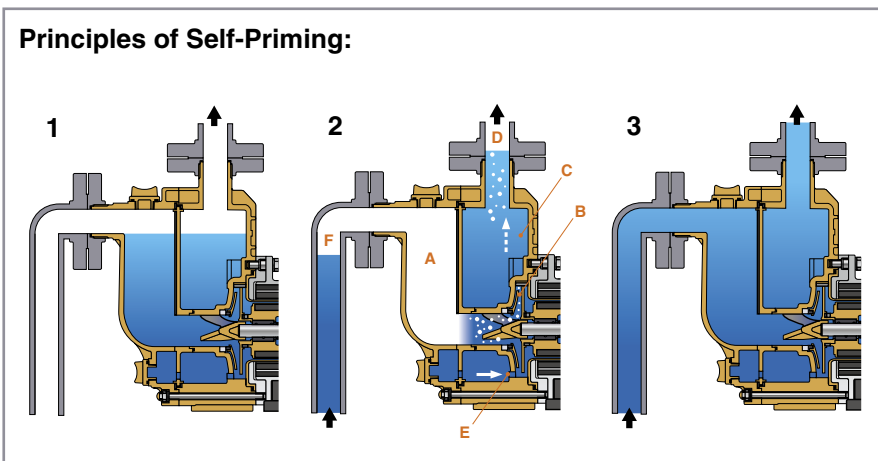

- 1** Prime the pump with liquid.
- 2** On starting, the pump will suck both gas and liquid into its inlet. This mixture moves through front case **A** to the front casing, where it is agitated by the impeller. The mixture is discharged through pump chamber **B** to rear case **C**, where gas and liquid separation then occurs. Gas is bled from the discharge port **D** while some liquid is retained. Liquid in the rear case **C** is fed back through circulation hole **E** to the front casing, where it is again mixed with entrained gas by the impeller. This recirculation & bleeding process continues until gas from the suction side **F** is completely expelled.
- 3** Once all gas is expelled, normal centrifugal pump operation is resumed. Sufficient liquid remains in the casing for subsequent self-priming once the pump is stopped.

Specifications

Model	Connection Suction X Discharge (mm)	Impeller	Cycle (Hz)	Min. capacity (L/min)	Standard specification (L/min-m)	Max. capacity (L/min)	Motor (kW 2p)	Resisting pressure limit (MPa)	Mass Less motor (kg)
SMX-F220	25 X 25	V	50	10	80 - 8.5	90	0.37	0.28	14
SMX-F221	25 X 25	T	50	10	100 - 12.5	155	0.75	0.28	14
		V	50		80 - 8.5	130			
SMX-F222	25 X 25	T	50	10	100 - 12.5	155	1.5	0.28	17.5
SMX-F441	40 X 40	T	50	10	150 - 11.8	190	0.75	0.33	15.5
SMX-F442	40 X 40	T	50	10	150 - 11.8	280	1.5	0.33	19

- The self-priming height limit noted above refers to a liquid equivalent to fresh water at 20°C. The self-priming height limit varies with the liquid temperature and the type of liquid.
- Temperature range of handled liquid: 0 to 80°C (The self-priming height limit decreases at high temperatures.)

Pump identification

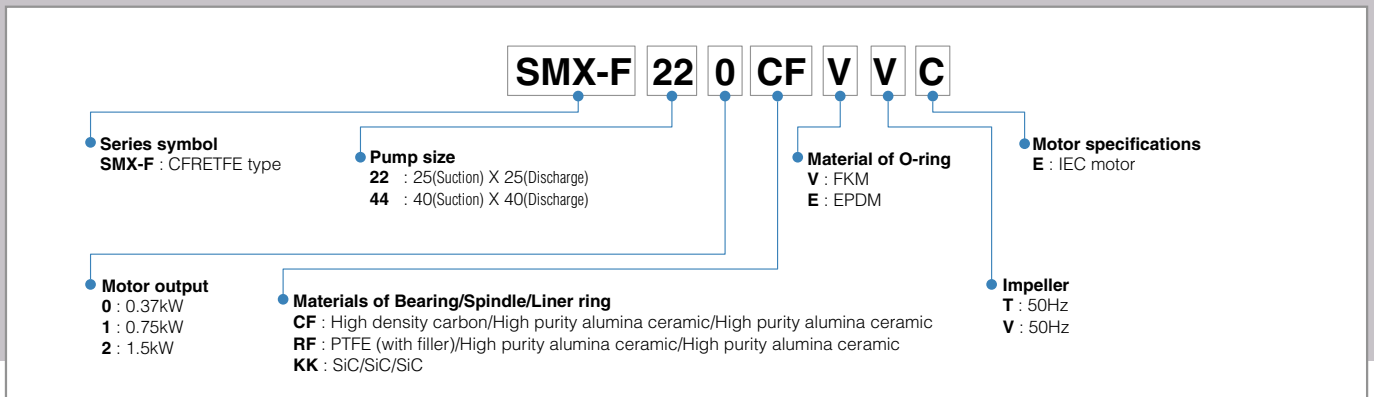

Dimensions in mm

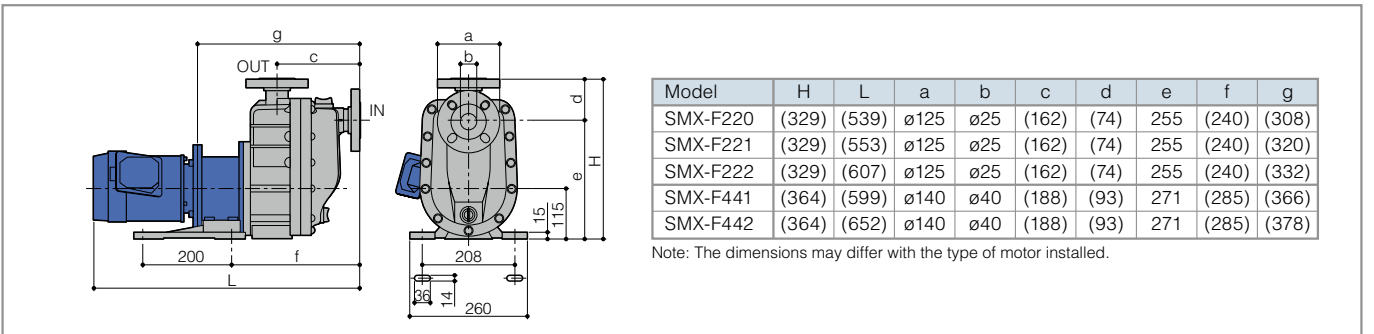

Pump identification

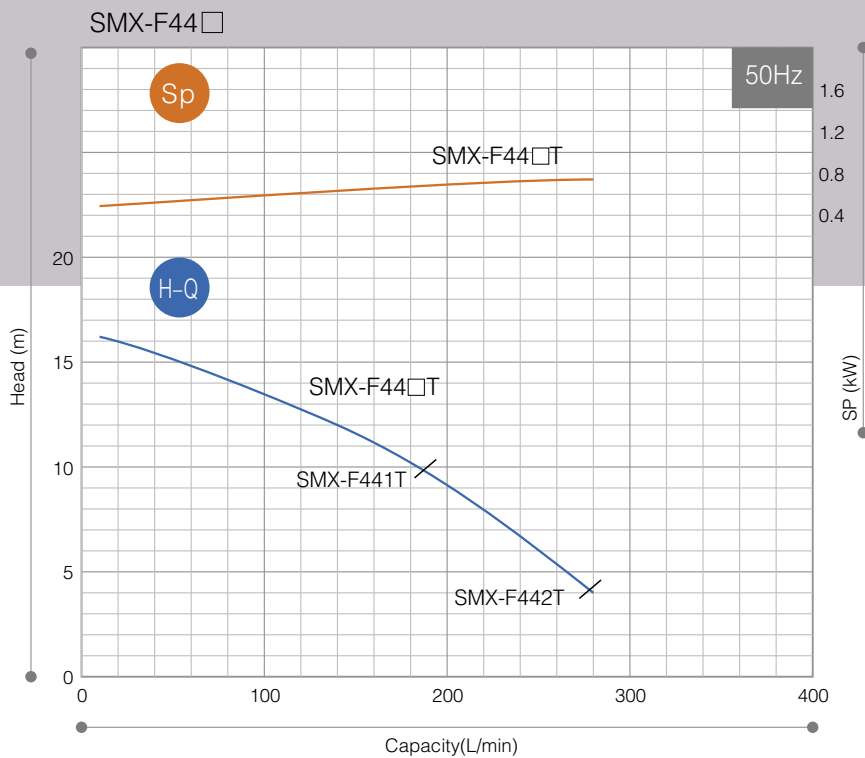
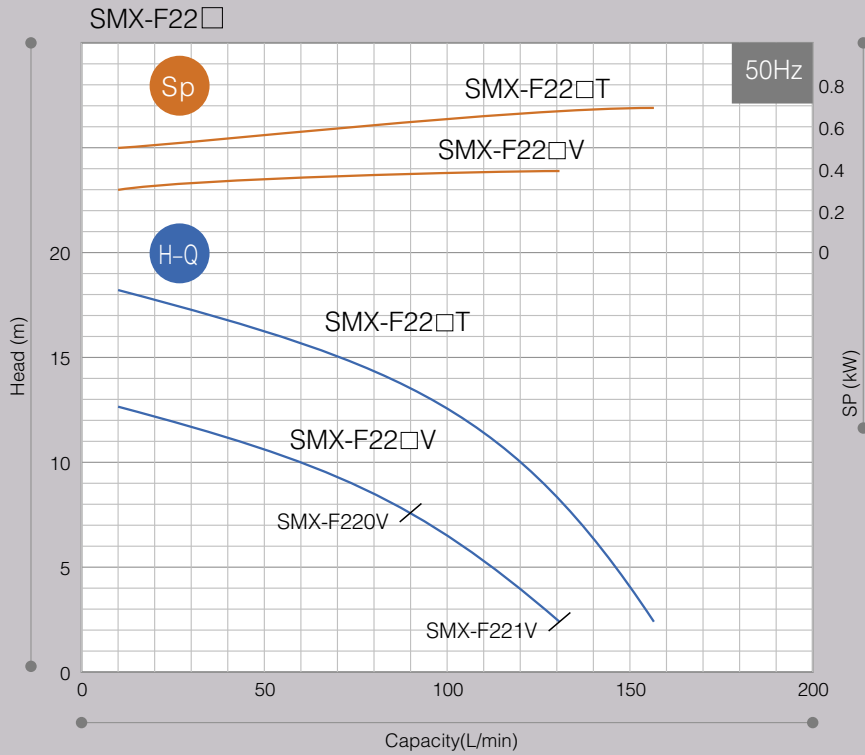

Precautions on the selection of pumps

1. The performance curves on this catalogue are based on the operation with 20°C clean water in flooded suction. Keep a margin (3% of the curves) when selecting the pump.

2. The magnetic pump cannot run continuously with a closed-discharge. Be sure to observe the minimum flow rate.

The minimum flow rate SMX-F22□: 10L/min
SMX-F44□: 10L/min

3. Select a pump model according to liquid specific gravity. Keep a margin (5% or more) for motor output.

Pump shaft power $Sp \times \text{Specific gravity} \times 1.05$ or more (margin) \leq Motor output

4. The self-priming performance (4m in 90 seconds) is based on the operation with 20°C clean water on the right piping condition. Self-priming performance varies with liquid temperature, characteristics and piping conditions. Obtain a rough guide of the highest possible self-priming height at each liquid specific gravity by the following formula.

The highest possible self-priming height [m] =
Self-priming height with clean water [m] / Liquid specific gravity

Self-priming considerations

1. The diameter of the piping on the suction side should be the same as that of the pumps inlet port (22□: 25 mm, 44□: 40 mm), and the length of the piping should be limited to less than 4.7m. A larger pipe diameter or longer piping could adversely affect the self-priming performance, or could even hinder the self-priming process itself.

2. In cases where the liquid level fluctuates, take the height from the lowest liquid level as the maximum self-priming height.

3. Always perform priming before first operation, and start the pump only after the pump chamber has been filled with the handled liquid.

4. To prevent early deterioration, avoid frequent start/stop of the pump.

5. If a foot valve is installed on the suction pipe, pipe resistance may increase so that the pump cannot suck liquid enough.

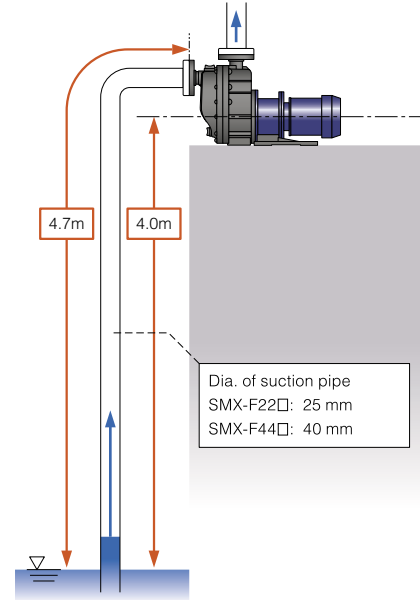

Optional accessories

Iwaki dry running protector DR series

Model DR is electric current sensing type dry running protector. It detects the decreased load current (lower limit) to stop the pump when it runs dry or runs with air sucking in. It can detect over-load, too.

- Current figure to be set is indicated on LCD.
- Both top/bottom figures can be set.
Top: Over-load
Bottom: Dry running, air sucking-in operation, operation with suction side closed
- Built-in current transformer
- DIN rail mounting
- It is unable to use DR when inverter is employed in the system.



Specification

50/60Hz

Model		DR-20
Motor power		380 to 440V three phase
Applied motor		0.75 to 15kW
Power control		100 to 240V single phase
Power	V	200 to 240V $\pm 10\%$ single phase
	Input	3.5W
Detective current		0.5 to 32.0A
Current transformer(CT)		Built-in
Outer dimension		D80 X W153 X H122

www.iwkipumps.jp

IWAKI CO.,LTD. 6-6 Kanda-Sudacho 2-chome Chiyoda-ku Tokyo 101-8558 Japan TEL : (81)3 3254 2935 FAX : 3 3252 8892

EUROPE / U.S.A.

European office	: IWAKI Europe GmbH	TEL: (49)2154 9254 0	FAX: 2154 9254 48
Austria	: IWAKI (Austria) GmbH	TEL: (41)26 674 93 00	FAX: 26 674 93 02
Belgium	: IWAKI Belgium N.V.	TEL: (32)13 67 02 00	FAX: 13 67 20 30
Denmark	: IWAKI Nordic A/S	TEL: (45)48 24 2345	FAX: 48 24 2346
Finland	: IWAKI Suomi Oy	TEL: (358)9 2745810	FAX: 9 2742715
France	: IWAKI France S.A.	TEL: (33)1 69 63 33 70	FAX: 1 64 49 92 73
Germany	: IWAKI Europe GmbH	TEL: (49)2154 9254 50	FAX: 2154 9254 55
Holland	: IWAKI Holland B.V.	TEL: (31)297 241121	FAX: 297 273902
Italy	: IWAKI Italia S.R.L.	TEL: (39)02 990 3931	FAX: 02 990 42888
Norway	: IWAKI Norge AS	TEL: (47)66 81 16 60	FAX: 66 81 16 61
Spain	: IWAKI Iberica Pumps, S.A.	TEL: (34)943 630030	FAX: 943 628799
Sweden	: IWAKI Sverige AB	TEL: (46)8 511 72900	FAX: 8 511 72922
Switzerland	: IWAKI (Schweiz) AG	TEL: (41)26 674 93 00	FAX: 26 674 93 02
U.K.	: IWAKI Pumps (UK) Ltd.	TEL: (44)1743 231363	FAX: 1743 366507
U.S.A.	: IWAKI America Inc.	TEL: (1)508 429 1440	FAX: 508 429 1386

ASIA / OCEANIA

Australia	: IWAKI Pumps Australia Pty Ltd.	TEL: (61)2 9899 2411	FAX: 2 9899 2421
China			
Hong Kong	: IWAKI Pumps Co., Ltd.	TEL: (852)2607 1168	FAX: 2607 1000
Shanghai	: IWAKI Pumps (Shanghai) Co., Ltd.	TEL: (86)21 6272 7502	FAX: 21 6272 6929
Guangzhou	: GFTZ IWAKI Engineering & Trading Co., Ltd.	TEL: (86)20 8435 0603	FAX: 20 8435 9181
Beijing	: GFTZ Iwaki Engineering & Trading Co., Ltd. (Beijing office)	TEL: (86)10 6442 7713	FAX: 10 6442 7712
Korea	: IWAKI Korea Co., Ltd.	TEL: (82)2 2630 4800	FAX: 2 2630 4801
Malaysia	: IWAKI Sdn. Bhd.	TEL: (60)3 7803 8807	FAX: 3 7803 4800
Singapore	: IWAKI Singapore Pte Ltd.	TEL: (65)6316 2028	FAX: 6316 3221
Indonesia	: IWAKI Singapore (Indonesia Branch)	TEL: (62)21 6906606	FAX: 21 6906612
Taiwan	: IWAKI Pumps Taiwan Co., Ltd.	TEL: (886)2 8227 6900	FAX: 2 8227 6818
Thailand	: IWAKI (Thailand) Co., Ltd.	TEL: (66)2 322 2471	FAX: 2 322 2477
Vietnam	: IWAKI Pumps Vietnam Co., Ltd.	TEL: (84)613 933456	FAX: 613 933399

()Country codes

⚠ Caution for safety use: Before use of pump, read instruction manual carefully to use the product correctly.

Actual pumps may differ from the photos. Specifications and dimensions are subject to change without prior notice. For further details please contact us.