

# Iwaki

## Electromagnetic Metering Pump

---

### EWN-R (Standard)

---

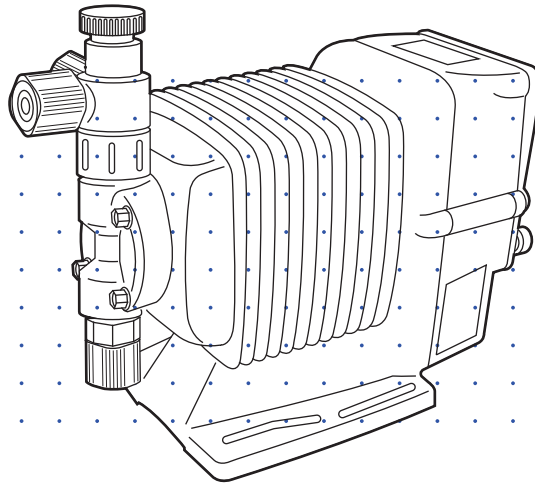

## Instruction manual

Thank you for choosing our product.



Please read through this instruction manual before use.



This instruction manual describes important precautions and instructions for the product. Always keep it on hand for quick reference.

## Order confirmation

After unpacking, check the following points. Contact us or your nearest dealer if the delivery is imperfect.

### a. Check if the delivery is as per order.

Check the nameplate to see if the discharge capacity, discharge pressure and voltage are as per order.

Iwaki Metering Pump	
MODEL	
PRESSURE	MPa
CAPACITY	L/H
VOLTAGE	V
CURRENT	A
FREQUENCY	Hz
MFG.No.	
Year :	
<b>IWAKI CO.,LTD.</b>  <small>TOKYO JAPAN</small>	
1P425395	<b>IP65</b> 

### b. Check if the delivery is damaged or deformed.

Check for transit damage and loose bolts.

# Contents

<b>Order confirmation</b> .....	2
<i>Safety instructions</i> .....	6
<b>Warning</b> .....	7
<b>Caution</b> .....	8
<b>Precautions for use</b> .....	10
<i>Outline</i> .....	12
<b>Introduction</b> .....	12
Pump structure & Operating principle .....	12
Features.....	14
Operational function .....	14
<b>Part names</b> .....	19
Pump.....	19
Operational panel .....	20
Basic displays & Pump states .....	21
<b>Identification codes</b> .....	23
Pump/Drive units .....	23
<i>Installation</i> .....	25
<b>Pump mounting</b> .....	25
<b>Pipework</b> .....	26
Tube connection .....	26
Check valve mounting .....	28
<b>Wiring</b> .....	30
Power supply/Earthing.....	30
External input cable.....	32
Connections .....	34

**Before operation**.....**37**

Points to be checked .....37

Retightening of pump head fixing bolts .....37

    Use of hexagon wrench instead of a torque wrench ..... 38

Degassing..... 38

Flow rate adjustment .....41

    Stroke rate adjustment .....42

    Stroke length adjustment..... 44

Before a long period of stoppage (One month or more)..... 45

**Operation programming** ..... **45**

Programming flow..... 46

Manual operation ..... 48

EXT operation..... 49

    EXT mode ..... 49

    EXT mode programming..... 50

User mode ..... 59

    STOP/Pre-STOP function ..... 60

    STOP/Pre-STOP function cancellation ..... 62

    OUTPUT function..... 64

    ANA-V/-R selection ..... 66

    Buffer ON/OFF selection..... 68

    PIN number entry .....70

Keypad lock .....72

    Keypad lock activation.....73

    Keypad lock release .....73

Calibration mode .....74

Unit change.....75

    spm indication.....75

**Troubleshooting..... 77**

**Inspection..... 79**

Daily inspection .....79

Periodic inspection .....79

**Wear part replacement..... 80**

Wear part list..... 80

Before replacement .....81

Valve set replacement .....81

Discharge valve set dismantlement/assembly .....81

Suction valve set dismantlement/assembly ..... 83

Spacer set replacement (Automatic air vent type) ..... 84

Air vent valve set replacement (Automatic air vent type) ..... 85

Diaphragm replacement ..... 85

**Exploded view..... 88**

Pump head, Drive unit & Control unit ..... 88

Pump head ..... 89

EWN-[B09•B11•B16•B21•C16•C21] [VC•VH•PC•PH•TC] ..... 89

EWN-[B31•C31•C36] [VC•VH•PC•PH•TC]..... 90

EWN- □FC .....91

EWN-C31PC/P6-V ..... 92

EWN-□SH & SH-H..... 93

EWN-Automatic air vent type..... 94

**Specification/ Outer dimension ..... 95**

Specification ..... 95

Pump unit ..... 95

Power cable.....97

Pump colour .....97

Outer dimensions..... 98

# Safety instructions

Read through this section before use. This section describes important information for you to prevent personal injury or property damage.

## ■ Pictorial indication

In this instruction manual, the estimated risk of degree caused by incorrect use is ranked with the following pictorial indications. First, fully understand information on the pictorial indications.



**WARNING**

Indicates mishandling could lead to a fatal or serious injury accident.



**CAUTION**

Indicates mishandling could lead to personal or property damage.

Pictorial indication accompanies each precaution, suggesting "Caution", "Prohibition" and "Requirement".

### Caution marks



Caution



Electrical shock

### Prohibition mark



Prohibition



Do not remodel

### Requirement mark



Requirement



Wear protectors



Earthing



## For exportation

Technology related to the use of goods in this instruction manual falls in the category of technology contained in the Foreign Exchange Order Attachment, which includes complementary export control of technology. Please be reminded that export license, which is issued by the Ministry of Economy, Trade, and Industry could be required, when this is exported or provided to someone even in Japan.

**WARNING****Turn off power before work**

Risk of electrical shock. Be sure to turn off power to stop the pump and related devices before work.



Electrical shock

**Stop operation**

On sensing any abnormality or danger, suspend operation immediately and inspect/solve problems.



Requirement

**Do not use the pump in anything other than a specified purpose**

The use of the pump in any purpose other than those clearly specified may result in failure or injury. Use this product in a specified condition.



Prohibition

**Do not modify the pump**

Remodelling the pump carries a high degree of risk. We are not responsible for any failure or injury results from remodelling.



Do not remodel

**Wear protective clothing**

Always wear protective clothing such as an eye protection, chemical resistant gloves, a mask and a work cap during dismantlement, assembly or maintenance work.



Wear protectors

**Do not damage the power cable**

Do not pull or knot the power cable or place a heavy stuff on it. Damage to the power cable could lead to a fire or electrical shock.



Prohibition

**Do not use the pump in a flammable atmosphere**

Do not place dangerous or flammable goods near the pump for your safety.



Prohibition

## CAUTION

### **A qualified operator only**

The pump must be handled or operated by a qualified person with a full understanding of the pump. Any person who is not familiar with this product should not take part in operation or management.



Requirement

### **Use a specified power only**

Do not apply any power other than the one specified on the nameplate. Otherwise, failure or fire may result. Also, be sure to earth the pump.



Prohibition

### **Do not run pump dry**

Do not run pump dry for more than 30 minutes (even when the pump runs for degassing). Otherwise, the pump head fixing screws may loosen and liquid may leak. Optimise your system in order for the pump not to run dry. If the pump run dry for a long period (for more than 30 minutes), the pump head and valve case may deform by friction heat and consequently leakage results.



Caution

### **Do not wet electric parts or wiring**

Risk of fire or electrical shock. Install the pump free from liquid spill.



Prohibition

### **Observe an applicable MSDS**

Take account of installation environment. Chemicals should be controlled in accordance with a MSDS.



Caution

### **Do not install or store the pump in the following places where...**

- Under a flammable atmosphere or in a dusty/humid place.
- Ambient temperature is beyond 0-40 degrees Celsius.
- Under direct sunlight or wind & rain.



Prohibition

### **Countermeasure against efflux**

Take a protective measurement against an accidental chemical overflow results from pump or piping breakage.



Requirement

**Do not use the pump in a water place**

The pump is not totally waterproof. The use of the pump in water or high humidity could lead to electrical shock or short circuit.



Prohibition

**Earthing**

Risk of electrical shock. Always earth the pump.



Earthing

**Install an earth leakage breaker**

An electrical failure of the pump may adversely affect related devices. Purchase and install an earth leakage breaker separately.



Caution

**Wear part replacement**

Follow instructions in this manual for wear part replacement. Do not dismantle the pump beyond the extent of the instructions.



Requirement

**Do no use a damaged pump**

Using a damaged controller could lead to an electric leak or shock.



Prohibition

**Disposal of the used pump**

Dispose of any used or damaged pump in accordance with relevant regulations. Consult a licensed industrial waste products disposing company.



Requirement

**Tighten the pump head**

Liquid may leak if pump head fixing bolts are loose. Tighten the bolts diagonally and evenly before initial operation. Also, periodically tighten the bolts for the prevention of leakage.



Caution

**Tightening torque**

EWN-B11•16•21, C16•21: 2.16 N•m      EWN-B31, C31•36: 2.55 N•m

**Solution compatibility**

This pump has been evaluated for use with water only. The suitability of this pump for use with liquids other than water, such as acid and alkaline, is the responsibility of the user. For liquids other than water, select the best-suited liquid end material combination using a chemical compatibility chart.



Caution

## Precautions for use

- Electrical work should be performed by a qualified operator. Otherwise, personal or property damage accident may result.



- Do not install the pump in the following places where...
  - Under a flammable atmosphere or in a dusty/humid place.
  - Under direct sunlight or wind & rain.
  - Ambient temperature is beyond 0-40 degrees Celsius.Protect the pump with a cover when installing it out of doors.

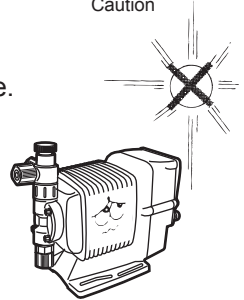

- Select a level location where is free from vibration and liquid can't stay. Fix the pump with M5 bolts so as not to vibrate. If the pump is installed at a tilt, the flow may reduce.

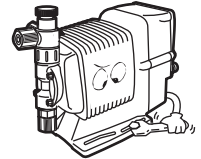

- When two or more pumps are installed, the pump operation interacts each other and vibration becomes significant, resulting in poor performance or failure of internal electrical devices. Select an installation location where tolerates vibration to enough degree.



- Keep a wide maintenance space around the pump.



- Install the pump as close to a supply tank.



- Install the pump in a cool and dark place when handling liquids that readily generate gas bubbles such as sodium hypochlorite or hydrazine solution. Flooded suction mounting is strongly recommended when using the pump with a supply tank.



- Be careful not to drop the pump onto the floor. A strong impact may reduce pump performance. Do not use a pump which has once damaged. Otherwise an electrical leak or shock may result.

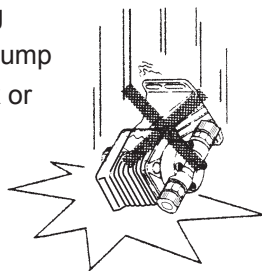

- The pump is a light water-/dust-proof structure of IP65, but is not totally waterproof. Do not have the pump wet with the liquid handled or rainwater.



Caution

- Never wet the pump head, control unit and drive unit. Otherwise, Failure or an accident may result. Immediately wipe off liquid if the pump has got wet.



Caution

- Do not close the discharge line during operation. Otherwise, liquid may leak or tubing may break.



Caution

- Do not remove the control unit. Note that an applicable control unit differs with each drive unit. Do not attach a control unit to a different drive unit. Otherwise, an electrical circuit or the drive unit may fail.



Caution

- Release the pressure from the discharge line before dismantling the pump or removing tubing. Otherwise, chemical liquid gushes out.



Requirement

- Be careful not to come in contact with residual liquid.



Caution

- Do not clean the pump or nameplate with a solvent such as benzene and thinner. This may discolour the pump or erase printing. Use a dry cloth or a wet cloth with water or neutral detergent.



# Outline

The information such as characteristics, features and part names are described in this section.

## Introduction

### ***Pump structure & Operating principle***

The EWN series is a diaphragm metering pump which consists of a pump head, drive unit and control unit. A diaphragm is directly driven by electromagnetic force.

#### **Principle of operation**

The pulse signal controls the electromagnetic force and spring force in order to make reciprocating motion. The reciprocating motion is transferred to a diaphragm through a plunger and then volumetric change occurs in the pump head. This action transfers liquid along with pump head valve action.

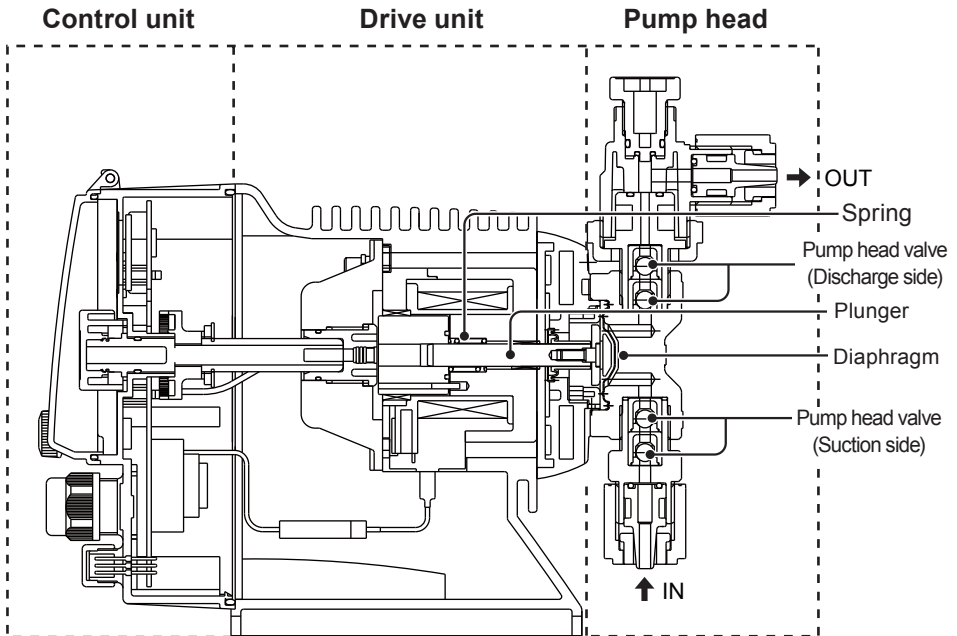

## • Automatic air vent type

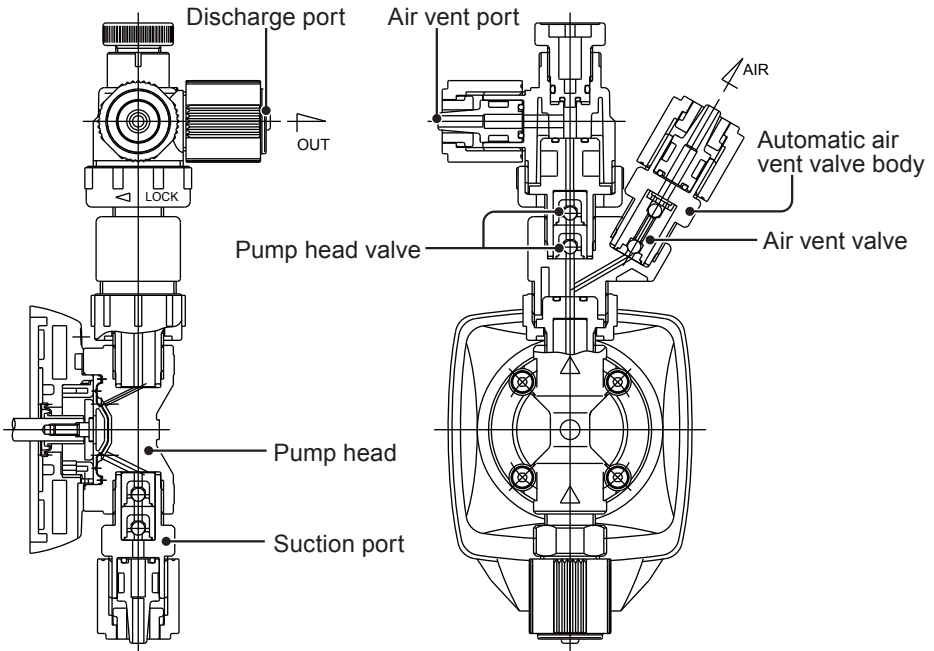

- Once air is entrained through the suction port, the working pressure difference between the pump head valve and the air vent valve separates entrained air from liquid.
- Entrained air is expelled to open air through the automatic air vent valve body.
- Only liquid is delivered to a discharge line through the discharge port. Note a small amount of liquid is expelled with entrained air.

## Features

---

- **Multi voltage**

All the EWN-R series is multivoltage type (100-240VAC) and can be selected without concern for local power voltage.

- **High resolution**

Digitally-controlled stroke rate range is 0.1-100%. The stroke length shifts for a fine flow adjustment.

- **Waterproof and dustproof structure (IP65)**

With the aim of improving resistance to exposure to liquid, the controller unit is installed on the back of the pump and the control panel is protected with a cover as standard equipment. A rubber gasket is provided between the pump head and the bracket to prevent water from entering from the periphery of the pump head.

\*This pump is not completely water resistant. Protect the pump with a cover when installing it out of doors.

## Operational function

---

- **Manual operation (see page 48)**

The start/stop of the pump by key operation

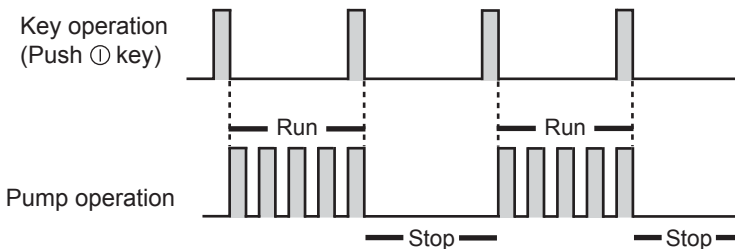

\*Manual operation can be done at any time during operation or stop.

- **EXT operation (see page 49)**

The pump operation by the external signal.

The external operation is available after the multiplier or divider programming.

### Multiplier programming (See page 51)

1-9999 shots can be programmed to one pulse signal.

\*In the EXT operation, the pump runs at the manual operation stroke rate.

\*The pump runs in 1:1 operation when the multiplier is programmed to 1.

Example) When the multiplier is programmed to 5, the pump makes five shots per signal.

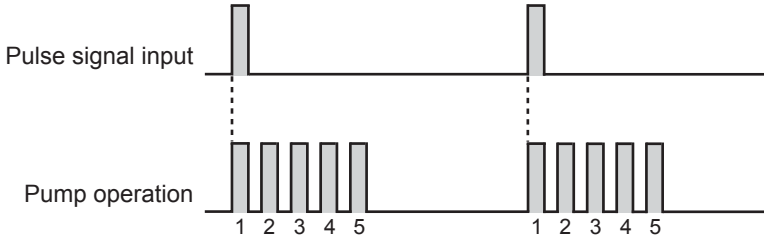

A buffer works when the pump receives the external signal before the programmed shots per signal is completed.

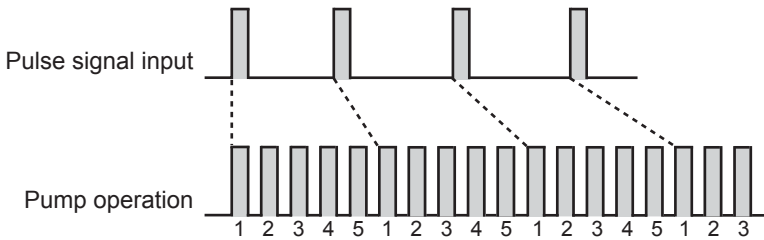

\*The buffer stores the external signals for up to 65535 shots.

### Divider programming (See page 53)

1-9999 pulse signals can be programmed to make one shot.

\*The pump can not run over a programmed stroke rate (max. 100%) even if the external signal is entered to run the pump faster.

\*The pump runs in 1:1 operation when the divider is programmed to 1.

Example) When the divider is programmed to 5, The pump makes one shot per 5-signal.

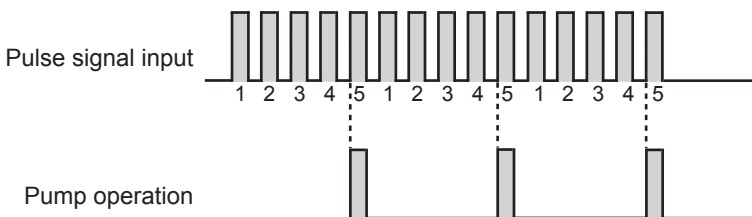

### ANA. R (analogue rigid) programming (See page 57)

The pump increases/decreases a flow rate in proportion to 0-20mA. Four (4-20, 20-4, 0-20, 20-0) programs are provided.

In "4-20" or "20-4" program a disconnection sensor works to stop the pump as a current value falls below 4mA ("DISCN" blinks on the screen). Check wiring as necessary. Pushing the start/stop key, this state is released.

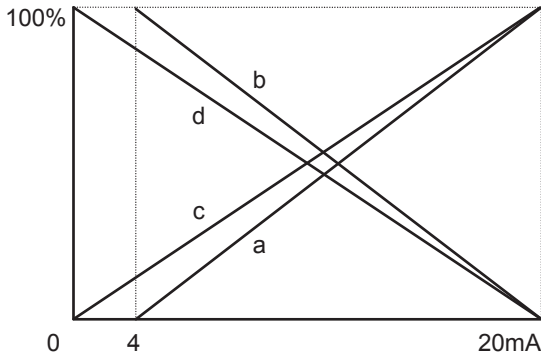

Condition  
The left graph is in the following programs.

- a. 4-20 (Default setting)
- b. 20-4
- c. 0-20
- d. 20-0

### ANA. V (analogue variable) programming (See page 55)

The pump increases/decreases a flow rate in proportion to 0-20mA.

Setting two points can draw a straight line. Depending on the position of the two points, 0 % may not come at 0mA in some cases. When the stroke rate could become over 100% at some mA due to the setting, pump speed is limited to 100%.

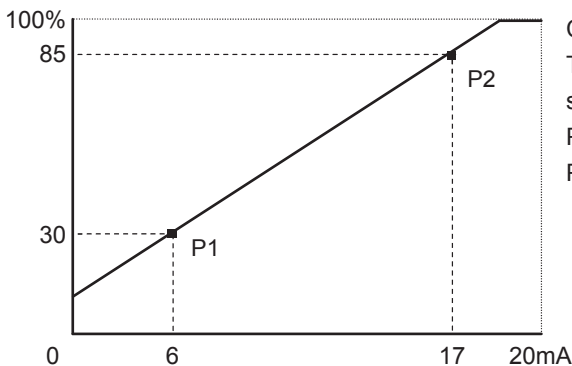

Condition  
The left graph is in the following setting.

- P1 = 6 mA, 30%
- P2 = 17 mA, 85%

● **STOP function (See page 60)**

The start/stop of the pump can be controlled by the external signal.

**When "NOR. OP" is selected...**

The pump stops while receiving the external signal via the STOP terminal.

\*The pump resumes operation when the STOP signal is released.

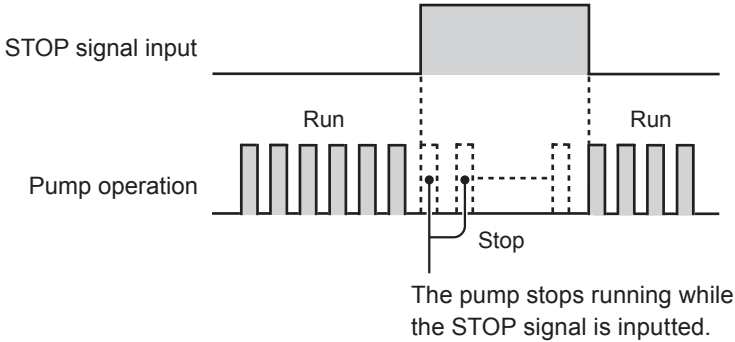

**When "NOR. CL" is selected...**

The pump runs while receiving the external signal via the STOP terminal.

\*The pump stops operation when the stop signal is released.

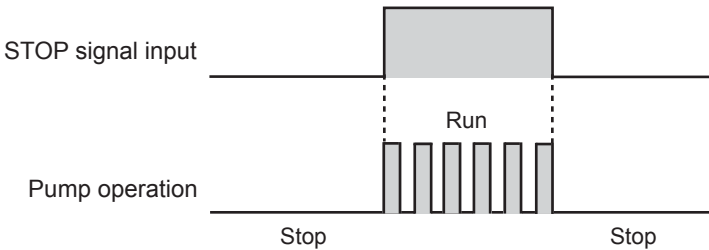

● **Pre-STOP function (See page 60)**

**When "NOR. OP" is selected...**

The STOP LED lights orange while the pump receiving the external signal via the Pre-STOP terminal (a contact is closed). Note the pump does not stop running.

**When "NOR. CL" is selected...**

The STOP LED stops lightening while the pump receiving the external signal via the Pre-STOP terminal (a contact is closed).

- **AUX function (See page 40)**

The pump runs at the maximum stroke rate while receiving the external signal via the AUX terminal. Use this function for degassing.

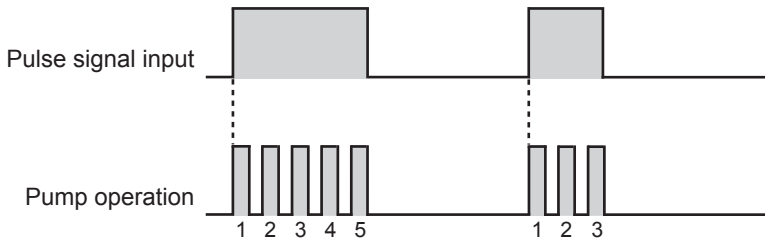

- **PRIME function (See page 40)**

The pump runs at the maximum stroke rate while both the UP and DOWN keys are pressed. Use this function for degassing.

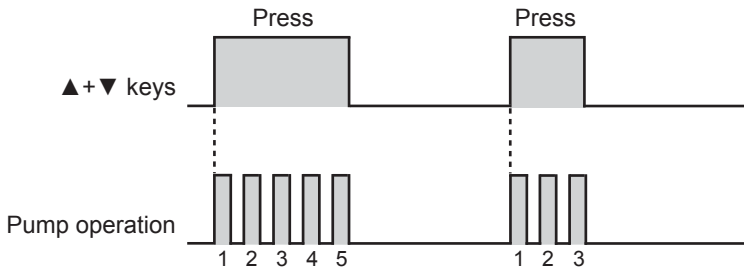

- **OUTPUT function (See page 64)**

Signals can be sent via the output terminal in sync with manual operation. The terminal can be set to on or off.

## Pump

### Adjusting screw

Used for opening the air vent port.

### Air vent port

Always connect a tube.  
Be sure to return the tube end to the supply tank or another container.  
The air vent port can rotate 90 degrees.

### Control unit

Used for the start/stop of the pump and stroke rate adjustment/programming.

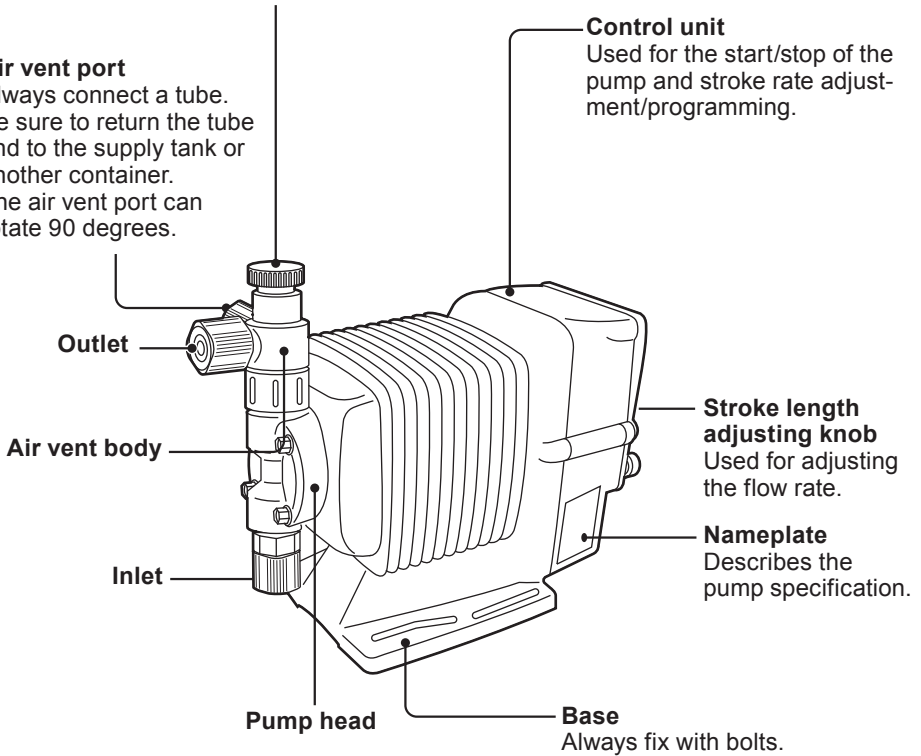

# Operational panel

## Display

An operational status, current mode and programmed value are shown here.

## Start/stop key

Used for starting/stopping the pump operation.

## EXT key

Used for entering the EXT mode.

## UP key

Used for increasing numeric values or selecting a programming mode.

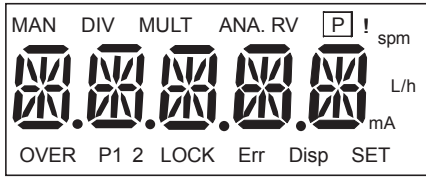

## LED

Lights as the pump is turned on and blinks at each shot.

## DOWN key







Used for decreasing numeric values or selecting a programming mode.

## DISP key

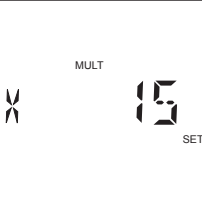
Used for checking flow information or changing units.

■ Basic displays & Pump states

	STOP LED lights redly	ON LED lights orange	ON LED lights greenly	ON LED blinks greenly
<p>MAN</p> <p>100.0%</p>	—	Manual wait state. Display shows stroke rate in %.	—	The pump is running in manual mode. Display shows stroke rate in %.
<p>MULT</p> <p>15</p>	—	—	EXT(Multiply) mode. The pump is waiting for the external signal.	EXT(Multiply) mode. The pump is making the displayed # of shots per signal.
<p>DIV</p> <p>10.5%</p>	—	—	EXT(Divide) mode. The pump is waiting for the external signal.	EXT(Divide) mode. The pump is running at the displayed stroke rate.
<p>ANA. R</p> <p>20.0%</p>	—	—	EXT(ANA. R) mode. The pump is waiting.	EXT(ANA. R) mode. The pump is running at the displayed stroke rate.
<p>ANA. V</p> <p>100.0%</p>	—	—	EXT(ANA. V) mode. The pump is waiting.	EXT(ANA. V) mode. The pump is running at the displayed stroke rate.
<p>AUX</p>	—	—	—	AUX mode. The pump is running at the maximum stroke rate.

	STOP LED lights redly	ON LED lights orange	ON LED lights greenly	ON LED blinks greenly
 <p>MULT X 15 SET</p>	—	EXT(Multiply) programming mode. The pump is set to make the displayed # of shots per signal.	—	—
 <p>DIV / 5 SET</p>	—	EXT(Divide) programming mode. The pump is set to make one shot for the displayed # of signals.	—	—
 <p>STOP</p>	Operation stop by the STOP signal. ON LED lights greenly.	—	—	—
 <p>-STOP</p>	STOP signal input in the manual wait state. ON LED lights orange.	—	—	—
 <p>MAN 100.0% LOCK</p>	Keypads are locked. Keypad operation is ineffective in this state. Release keypad lock before operation.			
 <p>PRIME</p>	—	—	—	PRIME mode. The pump is running at the maximum stroke rate.

## Identification codes

The model codes of the pump/drive units and the control unit represent the following information.

### Pump/Drive units

EWN - B 11 VC □ E R □ - □  
 a      b   c   d   e   f   g   h   i

#### a. Series name

EWN: Multivoltage electromagnetic metering pump

#### b. Drive unit code (Average power consumption)

B: 20W

C: 24W

#### c. Diaphragm effective diameter

09: 8mm                  11: 10mm                  16: 15mm

21: 20mm                  31: 30mm                  36: 35mm

#### d. Wet end materials

Code	Pump head	Valve	O ring	Valve seat	Gasket	Diaphragm
VC	PVC	CE	FKM	FKM	PTFE	PTFE + EPDM
VH		HC276	EPDM	EPDM		
PC	GFRPP	CE	FKM	FKM		
PH		HC276	EPDM	EPDM		
FC	PVDF	CE	PCTFE	—		
TC			FKM	FKM		
SH	SUS316	HC276	SUS316	—		

#### Automatic air vent type

Code	Air vent valve guide A	Air vent valve guide B	Valve	Separate pin	Valve seat	O ring
VC	PVC	PVC	CE	Titanium	FKM	FKM
VH			HC276	HC276	EPDM	EPDM

#### Material code

PVC : Transparent polyvinyl chloride      GFRPP : Glassfiber-reinforced polypropylene  
 PVDF : Polyvinylidene difluoride      EPDM : Ethylene-propylene rubber  
 FKM : Fluorine-contained rubber      PTFE : Polytetrafluoroethylene  
 HC276 : HASTELLOY C276      SUS316 : Austenite stainless steel  
 CE : Alumina ceramics

## e. Tube connection bore code

No.	Hose size (ID×OD)	Wet end materials	Pump model
No code*	ø4×ø6	VC/VH/PC/PH/TC/VC-C/VH-C/ VC-A/VH-A	EWN-09/-11/-16 & -21
	ø9×ø12	VC/VH/PC/PH	EWN-31 & -36
	ø10×ø12	TC	EWN-31 & -36
	ø6×ø12	VC-C/VH-C	EWN-09/-11/-16 & -21
	Rc 1/4	FC/SH/SH-H	EWN-11/-16/-21/-31 & -36
	IN: ø15×ø22 OUT: ø9×ø12	PC/P6-V	EWN-31
	IN/AIR: ø4×ø6 OUT: R1/4	PC/PH-H	EWN-11 & -16
1	ø4×ø9	VC/VH/PC/PH/VC-C/VH-C/ VC-A/VH-A	EWN-09/-11/-16 & -21
3	ø6×ø8	VC/VH/PC/PH/TC/VC-C/VH-C/ VC-A/VH-A	EWN-09/-11/-16 & -21
4	ø8×ø13	VC/VH/PC/PH	EWN-31 & -36
6	ø10×ø12	VC/VH/PC/PH	EWN-31 & -36
7	ø1/4"×ø3/8"	VC/VH/PC/PH/TC/VC-C/VH-C/ VC-A/VH-A	EWN-09/-11/-16 & -21
8	ø3/8"×ø1/2"	VC/VH/PC/PH/TC	EWN-31 & -36
9	Rc1/4	VC/VH/PC/PH/TC/VC-C/VH-C	EWN-09/-11/-16/-21/-31 & -36
23	ø6×ø12	VC	EWN-11/-16/-21/-31 & -36
24	ø5×ø8	VC/TC/VC-C	EWN-09/-11/-16 & -21
1/27	IN: ø4×ø9 OUT: R1/4	PC/PH-H	EWN-11 & -16
3/27	IN: ø6×ø8 OUT: R1/4	PC/PH-H	EWN-11 & -16
7/27	IN: ø1/4"×ø3/8" OUT: R1/4	PC/PH-H	EWN-11 & -16

\* No code. ø4×ø6 and ø6×ø12 are equipped to the EWN-09, -11, -16 & -21 (the VC or VH-C types).

## f. Power code

E: European cord

## g. Control unit function code

R: Standard

## h. Special version code

C: High compression type

H: High pressure type

V: High viscosity type

A: Automatic air vent type

## i. Special configuration code

# Installation

*This section describes the installation of the pump, tubing and wiring. Read through this section before work.*

## **!** Observe the following points when installing the pump.

- Be sure to turn off power to stop the pump and related devices before work.
- Upon sensing abnormality or danger, stop the work immediately. Remove problems before resuming work.
- Do not place dangerous or flammable goods near the pump for your safety.
- Risk of an electrical leak or shock. Do not use a damaged pump.

## Pump mounting

*Select an installation location and mount the pump.*

### Necessary tools

- Four M5 bolts (pump mounting)
- Adjustable wrench or spanner

### 1 Select a suitable place.

Always fix the pump on a flat floor free of vibration. See page 10 for detail.

Flooded suction is recommended when handling a gaseous liquid such as sodium hypochlorite.

### 2 Fix the pump by the M5 bolts.

Be sure to fix the pump at four points.

#### NOTE

Install the pump horizontally. If the pump is installed at a tilt, the flow may reduce.

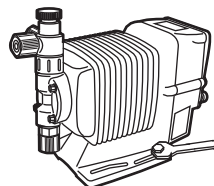

# Pipework

Connect tubes to the pump and install a check valve.

## Before operation

- Cut the tube ends flat.

Tube end (Side view)

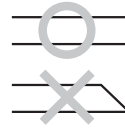

## Necessary tools

- Adjustable wrench or spanner

## Tube connection

- Pass a tube into the fitting nut and hose stopper and then slide it down to the hose adapter as far as it will go.
- Fit the tube end (hose adapter) to the fitting. Then hand tighten the fitting nut.
- Retighten the fitting nut by turning it 180 degrees with an adjustable wrench or spanner.

\*The plastic fitting nut may be broken if it is tightened too much.

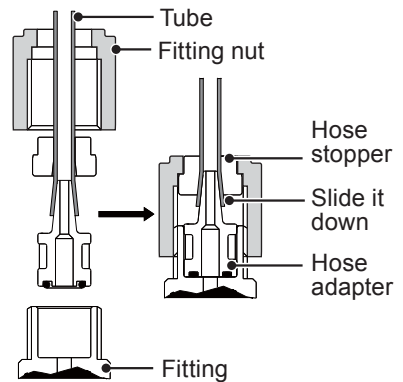

- 1 Connect tubes into the inlet and outlet.**

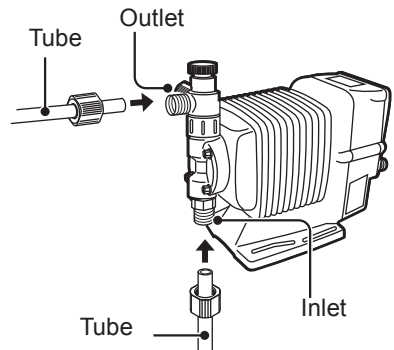

## 2 Connect an air bleed tube into the air vent port.

Place the tube end in the supply tank or another container.  
For the automatic air vent type, connect another air bleed tube into the automatic air vent valve body as well.

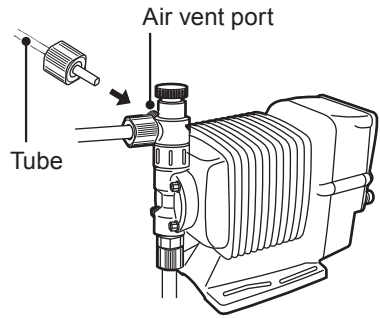

## 3 Direction of the air vent port.

The air vent port can rotate 90 degrees.

- Turn the lock nut anticlockwise.
- Adjust the direction of the air vent port.
- Turn the lock nut clockwise and fix it, holding the air vent body A.
- Further tighten the lock nut by turning it 90 degrees with an adjustable wrench or spanner.

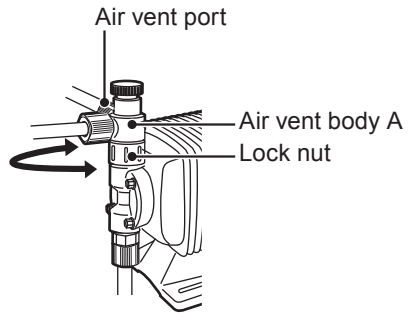

### NOTE

The air vent port is not provided to the EWN-FC type. Purchase Install an air vent valve.

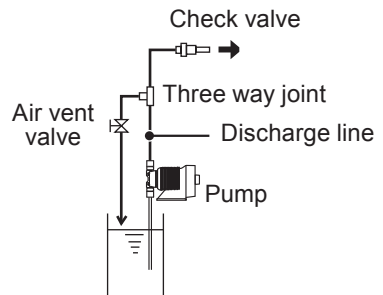

## Check valve mounting

Install an optional check valve to the EWN (or a back pressure valve to the FC type) for the prevention of a back flow, siphon and overfeeding.

In the following cases be sure to install the check valve.

- The suction side liquid level is higher than the discharge side (See the diagram below). Or an injection point is below the suction side liquid level at atmospheric pressure.

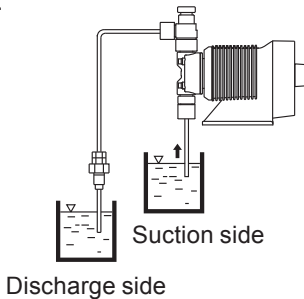

- The elevation difference between two liquid levels is five meters or below, even if the discharge side liquid level is higher than the suction side.

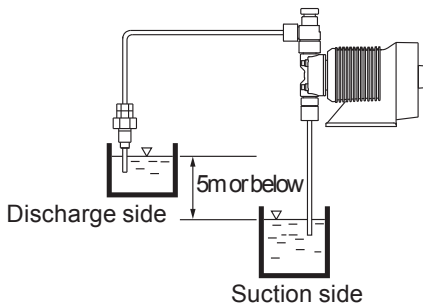

- Suction side pressure is higher than the discharge side pressure.

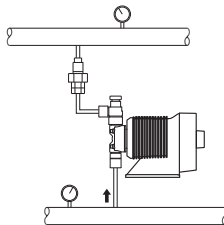

- Discharge pressure (including pipe resistance and discharge head) is below 0.13MPa. (0.049MPa for B31 and C36).

1

## Mount the check valve at the discharge tube end.

\*The CAN/CBN check valve and the BVC back pressure valve have R1/2 and R3/8 thread connections as well as tube connection. Cut off and adjust the connection length to fit the check valve into tubing.

### CAN check valve

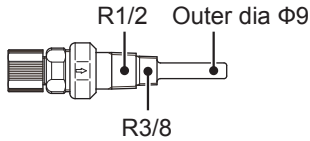

### BVC back pressure valve

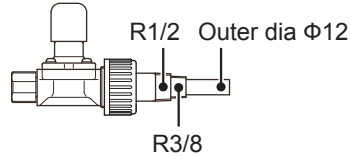

\*The CBN check valve of which the both ends are tube connection is also available. Contact us or your nearest dealer.

### CBN check valve

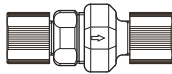

## NOTE

Periodically clean or replace the check valve with new one because it may be clogged by crystal.

## Tubing layout

### Flooded suction application

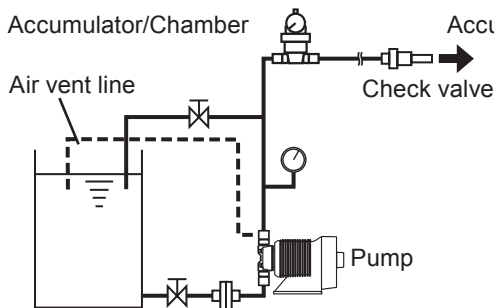

### Suction lift application

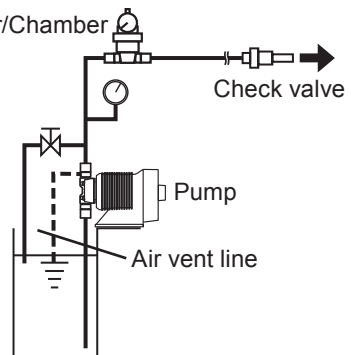

\*Flooded suction is recommended when handling a gaseous liquid such as sodium hypochlorite. For the automatic air vent type, keep a suction head at 1m or below. Otherwise, air vent valves may not function. Before resuming operation, always perform degassing by using the adjusting screw.

## Wiring

*Wiring for the power source and external signal.*

### **!** Observe the following points during wiring work.

- Electrical work should be performed by a qualified operator. Always observe applicable codes or regulations.
- Observe the rated voltage range. Otherwise the electrical circuit on the control unit may break.
- Do not perform wiring work while the power is on. Otherwise, an electrical shock and short circuit may result, and consequently the pump may fail. Be sure to turn off power before wiring work.
- Be careful for the power not to be turned on during work.
- Replacement of a power cable should be conducted by a manufacturer, his agency or a skilled person. Otherwise, an accident may result.

### **Necessary tools**

- Adjustable wrench or spanner
- Phillips screw driver
- Precision screw driver

## **Power supply/Earthing**

Check that the main power is turned off.

### **1 Insert the plug all the way seated in a jack.**

This product have two power wires and one earth wire, and is classified as class I.

\*Make sure the earth plug is seated in securely as well.

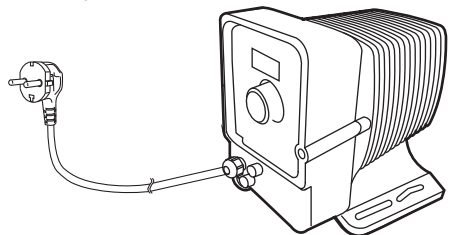

## NOTE

- Do not share a power source with a high power equipment which may generate surge voltage. Otherwise electronic circuit may fail. The noise caused by the inverter also affects the electronic circuit.
- Power voltage should be charged at a sitting via a switch or a relay. Otherwise CPU may malfunction. See page 32 for the precautions for ON-OFF control by the relay.

### Apply the power at a sitting

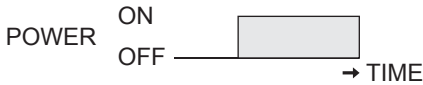

### Do not apply gradually

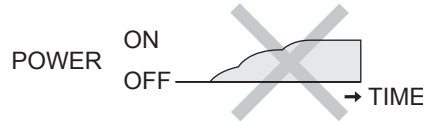

### Surge voltage

The electronic circuit in the control unit may fail due to surge voltage. Do not place the pump close to the high power equipment of 200V or more which may generate large surge voltage.

If the use near the high power equipment is inevitable, take any of the following measures.

- Install a surge absorption element (ex. a varister with capacity of 2000A or more) via power cable.

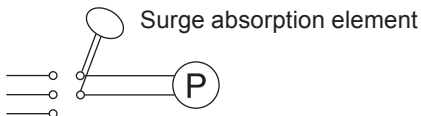

### Recommended varistors

Panasonic ERZV14D431

KOA NVD14UCD430

See manufacturer's catalogues for detail.

- Install a noise cut transformer via power cable.

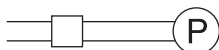

Noise cut transformer

### **Precautions for ON-OFF control by the relay**

The control unit is equipped with CPU. Always start/stop the pump by the STOP signal. Do not start/stop the pump by turning ON/OFF power because it may adversely affect CPU.

If there is no choice but to turn ON/OFF power, observe the following points.

- Do not turn ON/OFF the power more than six times per hour.
- When using a relay for ON-OFF operation, its contact capacity should be 5A or more. Contact point may fail if contact capacity is less than 5A.
- If the contact capacity of 5A is used for the EWN, the maximum ON/OFF operation is about 150,000 times. Use the relay with the contact capacity of 10A or more when making ON-OFF operation over 150,000 times or sharing a power source with a large capacity equipment. Otherwise a contact may fail by surge voltage.
- Use non contact transistor relay as necessary (ex. OMRON G3F). See manufacturer's catalogues for detail.

### ***External input cable***

---

*Use DIN 4- or 5-pin female connector. We recommend the use of Binder connector (German manufacturer). Contact us for detail.*

*Binder connector*

*5-pin : 713 series 99-0436-10-05      External input*

*4-pin : 715 series 99-0430-15-04      Level sensor*

*Connect input cables according to the following procedures. See manufacturer's instructions when using other connectors than Binder.*

### **Points to be checked**

- Check that the main power is turned off.  
The pump is still charged right after turning off power. Wait for one minute before wiring.

## NOTE

- Do not install the EXT/STOP signal wires in parallel with a power cable or combine them in a concentric cable (ex. 5 wires cable). Otherwise noise is generated through the EXT/STOP signal wires due to induction effect and it results in malfunction or failure.
- When using the SSR (Solid State Relay) for the EXT/STOP signal input, see the recommended products below. Any SSR other than the recommended ones can cause malfunction. See manufacturer's information such as catalogues for detail.
  - OMRON G3FD-102S or G3FD-102SN
  - OMRON G3TA-IDZR02S or G3TA-IDZR02SM
- When using a contact type relay for the EXT/STOP signal input, the minimum application load should be 5mA or below.

\*Use either a no-voltage contact or an open collector for the external signal.

\*Set pulse duration in 10-100ms (100Hz or below)

- 1 Take apart the DIN connector as necessary to pass a cable through it.**  
A cable diameter should be  $\varnothing 4 - \varnothing 6$ . Otherwise, the DIN connector can not seal the cable.

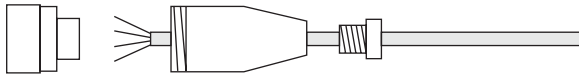

- 2 Strip the wire ends to connect and secure them to each position.**  
A cross sectional area of a wire should be  $0.75\text{mm}^2$  or below.

- 3 Assemble the DIN connector.**  
Pull the cord lightly so as to check it is secured enough. If it is loose, the DIN connector can not seal the cable.

## ■ Connections

### • Level sensor

The EWN have two stage level sensor, the Pre-STOP and STOP alarms. Connect the pre-alarm signal to the Pre-STOP and the alarm signal to the STOP. The pre-alarm functions just to notify a low liquid level by flashing the LED orange while the pump is running. Use the STOP and COM2 when just one signal is used.

#### • When using an open collector...

Pay attention to polarity. Pre-STOP and STOP are plus(+), and COM2 is minus(-).

(Maximum 1.8mA at 5V)

#### • When using a contact...

The contact should be designed for an electronic circuit. The minimum application load should be 1mA or less.

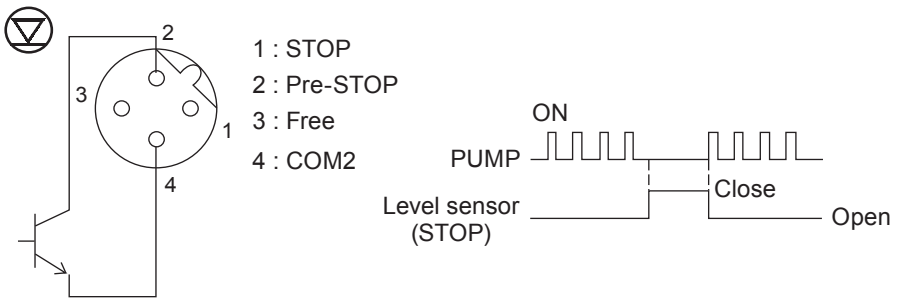

### • Stop function

The pump stops running as receiving the external signal. Use the STOP and COM2.

#### NOTE

Frequent ON-OFF operation should be controlled via the Stop function. Otherwise, the number of ON-OFF times (turning on/off power) should be restricted to six times per hour.

• **Pulse signal**

In the EXT (MULT or DIV) mode, the pump runs along with multiplier or divider as receiving the pulse signal.

• *When using an open collector...*

Pay attention to polarity. Pulse is plus(+), and COM1 is minus(-).  
(Maximum 1.8mA at 5V)

• *When using a contact...*

The contact should be designed for an electronic circuit. The minimum application load should be 1mA or less.

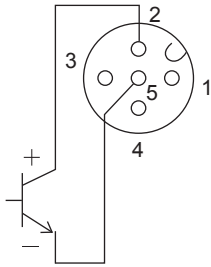

- 1 : Free
- 2 : Pulse
- 3 : Free
- 4 : Free
- 5 : COM1

• **Analogue signal**

In the EXT (ANA.R or ANA.V) mode, the pump runs in a proportional control as receiving the analogue signal.

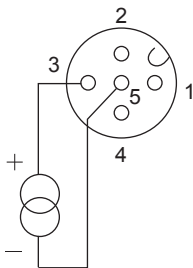

- 1 : Free
- 2 : Free
- 3 : ANA
- 4 : Free
- 5 : COM1

### • OUTPUT signal

The pump sends out the OUTPUT signal along with injections or the STOP signal along with the external STOP signal input via a Photo MOS relay.

\*The maximum applied voltage is 24VAC/DC.

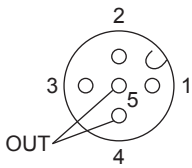

- 1 : Free
- 2 : Free
- 3 : Free
- 4 : OUT
- 5 : COM

### • AUX signal

The pump runs at the max stroke rate as receiving the AUX signal.

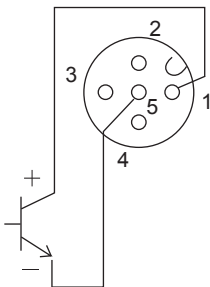

- 1 : AUX
- 2 : Free
- 3 : Free
- 4 : Free
- 5 : COM1

# Operation

Run the pump after pipework and wiring is completed.  
This section describes pump operation and programming.

## Before operation

Check the flow rate, tubing and wiring. And then perform degassing and flow rate adjustment before starting operation.

### **Points to be checked**

Before operation, check if...

- Liquid level in the supply tank is enough.
- Tubing is securely connected and is free from leakage and clogging.
- Discharge/suction valves are opened.
- Proper power voltage is applied to the pump.
- Electrical wiring is correct and is free from the risk of short circuit and electrical leakage.

### **Retightening of pump head fixing bolts**

#### **Important**

The pump head fixing bolts may loosen when plastic parts creep due to temperature change in storage or in transit.

This can lead to leakage. Retighten the pump head fixing bolts before starting operation.

Always tighten the bolts diagonally. See below for the tightening torque at each model.

#### **Tightening torque**

Model identification code	Torque	Bolts
EWN-B09•11•16•21	2.16 N•m	M4 Hex. socket head bolt
EWN-B31	2.55 N•m	M4 Hex. socket head bolt
EWN-C16•21	2.16 N•m	M4 Hex. socket head bolt
EWN-C31	2.55 N•m	M4 Hex. socket head bolt
EWN-C36	2.55 N•m	M5 Hex. socket head bolt

\*Tighten fixing bolts once every three months.

## ■ Use of hexagon wrench instead of a torque wrench

Fasten the fixing bolts as tight as can be by the hand with the straight long part of a hexagon wrench (a) and further turn the bolts clockwise 90 degrees with the short part (b).

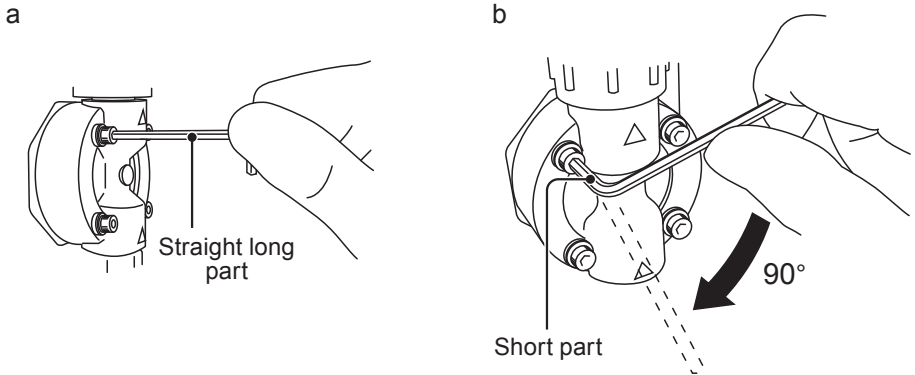

## ***Degassing***

---

*The gas needs to be expelled from the pump and tubing by degassing. Normal performance can not be obtained with gas in the pump. Conduct degassing in the following cases.*

- When the pump starts to run for the first time
- When the flow rate is too low
- After liquid is replaced in the supply tank
- After a long period of stoppage
- After maintenance and inspection

### NOTE

---

- Both gas and chemical come out together through air bleed tube. Place the end of the tube in the supply tank or another container.
  - Some chemicals may cause skin trouble or damage component parts. When your hand or component parts get wet with chemical liquid, wipe off immediately.
  - For the automatic air vent type, this process is not necessary as long as air vent valves work effectively. But if air lock prevents this function, follow this process to expel gas.
-

### Points to be checked

- An air bleed tube is connected to the air vent port.
- For the automatic air vent type, another air bleed tube is connected to the automatic air vent body.

Air bleed tube

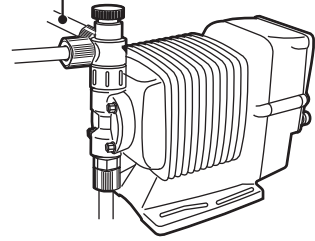

## 1 Turn on power.

The ON LED lights and a display related to the current mode appears on the screen.

\*The pump enters the wait state in the manual mode when turning on power with a default setting. The pump calls up the last screen at a shutoff if it was not in a default setting.

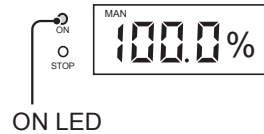

## 2 Rotate the adjusting screw two revolutions anticlockwise to open the air vent port.

\*Do not rotate it three revolutions. Otherwise, liquid may come out from the air vent port.

Adjusting screw

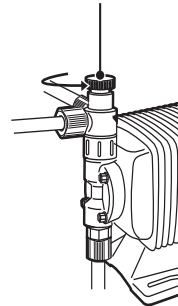

### 3 Run the pump at the maximum stroke rate.

Select a convenient way from the following.

- Set the stroke rate to 100% and run the pump manually.

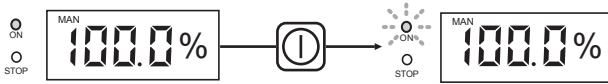

- Enter the external signal via the AUX terminals.

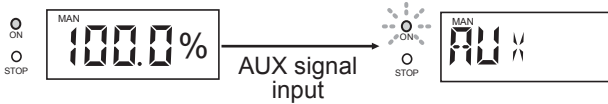

- Press and hold both the UP and DOWN keys.



### 4 Keep the pump running for more than ten minutes for degassing.

### 5 Stop the pump by...

- pushing the start/stop key once or
- stopping the AUX signal or
- releasing the UP and DOWN keys

### 6 Rotate the adjusting screw clockwise to close the air vent port.

### 7 Check liquid is discharged.

\*Degassing is required again if the pump does not discharge liquid.

### 8 Check connections for leakage.

Degassing has now been completed.

\*The air vent port is not provided to the FC type. Install an air vent valve on the discharge line for degassing. See page 27 for detail. Also, the FC type has the threaded outlet & inlet, so that a tube can not be fit directory. Use general joints for tubing.

## **Flow rate adjustment**

---

*A flow rate can be adjusted by the stroke rate and stroke length.*

The stroke rate is indicated in %. 100% stroke rate means the maximum flow rate. Stroke rate adjustment is a main way to adjust a flow rate.

Stroke length is the moving distance of the plunger.

A flow rate per shot can be controlled by changing stroke length. The widest moving distance is defined as 100% stroke length.

First adjust the flow rate by stroke rate adjustment. Use stroke length adjustment for the range where stroke rate adjustment can not reach.

Determine a suitable stroke length and stroke rate, taking account of the pump operating condition and liquid characteristics.

The following procedure is recommended.

- 1 Change a stroke rate with stroke length 100% to adjust a flow rate.**
  - See "Stroke rate adjustment" on page 42 and "Stroke length adjustment" on page 44 for detail.
- 2 Measure a flow rate.**
- 3 If the flow rate is lower than a specified level, increase the stroke rate and measure the flow again.**
- 4 Change the stroke length for fine adjustment.**
- 5 Measure the flow again to see the specified level is obtained.**

## Flow rate, stroke rate and stroke length

### B type

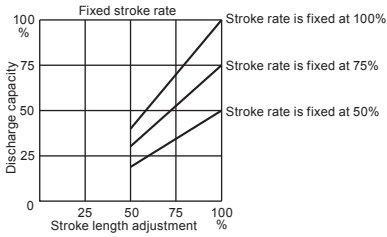

### C type

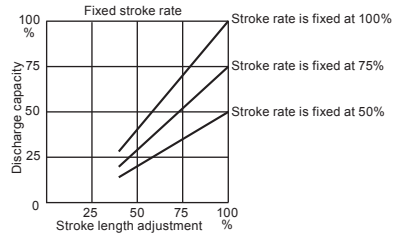

## Precautions of flow rate adjustment

- **When back pressure is high**

Set stroke length to 100% and adjust the flow by changing a stroke rate.

- **When the flow rate per shot greatly influences the reaction in neutralization or titration application**

Shorten the stroke length to reduce the flow rate per shot. And then adjust the flow by changing a stroke rate.

- **When pumping gaseous liquid such as sodium hypochlorite (NaClO) and hydrazine solution (N<sub>2</sub>H<sub>2</sub>O<sub>2</sub>)**

Set stroke length to 100% and adjust the flow by changing stroke rate.

Air lock may occur when stroke length is set short.

### ■ Stroke rate adjustment

Stroke rate can be set by keypad operation.

The stroke rate can be programmed from 0.1 to 100%.

The relation between a flow rate\* and stroke rate is shown as below.

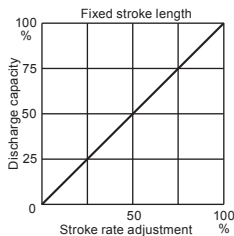

\*The flow rate described on the nameplate is at 100%.

## 1 Turn on power and call up manual mode.

Enter manual mode to indicate stroke rate on the screen.

- Push the start/stop key when "MULT", "DIV", "ANA.R" or "ANA.V" is on the screen.
- When "STOP" or "-STOP" appears on the screen, see "STOP function cancellation" on 62 page and release the STOP function.



## 2 Use the UP or DOWN key to adjust stroke rate.

- The stroke rate increases/decreases as pushing the UP/DOWN keys.
- Press and hold either key for three seconds for quick change. Quick change stops at 0.1% or 100%. 0.1% or 100% skips to 100% or 0.1% when the key is released and pushed again.

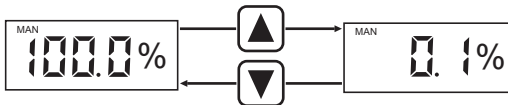

## 3 Push the start/stop key.

The ON LED starts to blink as the pump starts to run.

- The ON LED blinks in sync with the pump operation.



## ■ Stroke length adjustment

Stroke length can be adjusted when the moving distance of the plunger is changed by the stroke length adjusting knob.

The stroke length adjustment range is 50-100% for the B type, 40-100% for C type.

The relation between a flow rate\* and stroke length is shown as below.

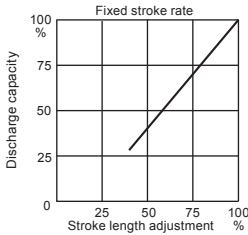

\*The flow rate described on the nameplate is at 100%.

### NOTE

Do not rotate the stroke length adjusting knob when the pump is not running.

## 1 Turn on power and push the start/stop key to run the pump.

The ON LED blinks during operation.

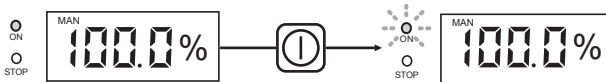

## 2 Rotate the stroke length adjusting knob and adjust a flow rate while the pump is running.

Stroke length adjusting knob

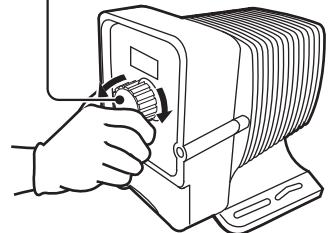

## ***Before a long period of stoppage (One month or more)***

### **Clean the insides of pump head and tubing.**

- Run the pump with clean water for about thirty minutes to rinse the insides of the pump head and tubing.

### **Before unplugging the pump**

- Always stop the pump by key operation. Wait for three seconds before unplugging the pump. Otherwise, the last key operation to stop the pump may not be put in memory. In this case the pump unintentionally starts to run as powered on, discharging liquid.

### **When the pump does not transfer liquid at resuming operation.**

- Clean the valve sets, removing foreign matters.
- If gas is in the pump head, expel gas and readjust the flow rate. See "Degassing" on page 38 and "Flow rate adjustment" on page 41 for detail.

## **Operation programming**

*The pump operation is programmed and controlled by a control unit.*

*The pump is controlled in different ways at each operation mode.*

### **Default setting and setting range**

Parameters	Default setting	Setting range	Step
Stroke rate* <sup>1</sup>	100.0%	0.1-100.0%	0.1* <sup>2</sup>
Multiply/Divide/Analogue selection	DIV	ANA-V, ANA-R, /NNNN, XNNNN	-
Divider	1	1-9999	1* <sup>3</sup>
Multiplier	1	1-9999	1* <sup>3</sup>
Analogue variable	-	0-20mA, 0-100%	1* <sup>3</sup>
Analogue rigid	4-20	4-20, 20-4, 0-20, 20-0	-
STOP function* <sup>4</sup>	NOR.OP	NOR.OP, NOR.CL	-
Pre-STOP function	NOR.OP	NOR.OP, NOR.CL	-
Analogue mode selection	ANA-R	ANA-R, ANA-V	-
Output function	STOP	STOP, SPM	-
CODE programming	00000	00000-99999	1
Unit selection	%	%, GPH, L/h, ml/min	-

\*1 The upper limit stroke rate in EXT mode

\*2 The flow rate increases/decreases as pushing the UP/DOWN keys. Press and hold either key for quick change.

\*3 A figure increases/decreases as pushing the UP/DOWN keys. Press and hold either key for quick change.

\*4 Note that the pump starts to run as returning to the wait state in the manual mode as long as the pump is receiving the STOP signal with "NOR.CL".

# Programming flow

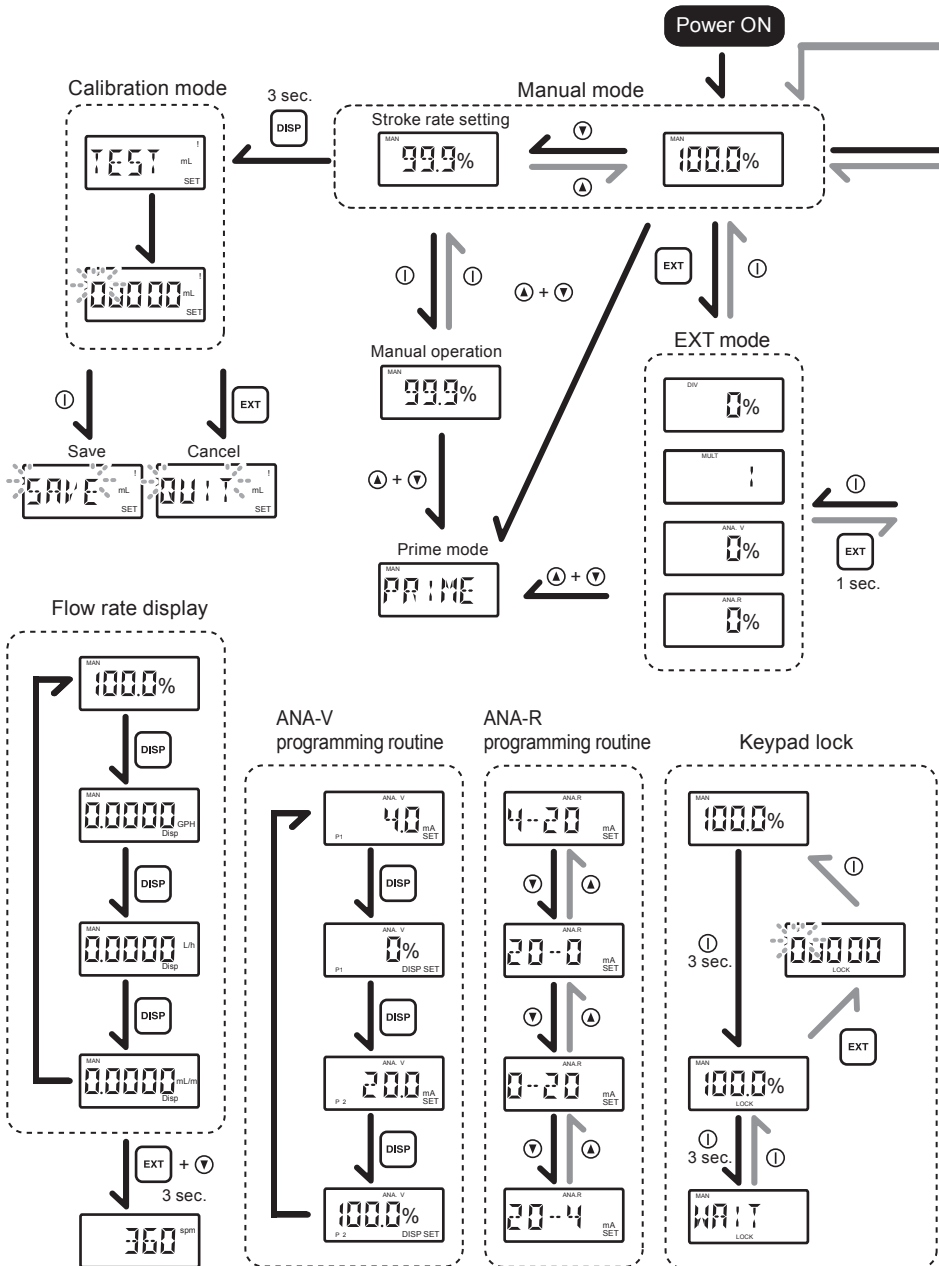

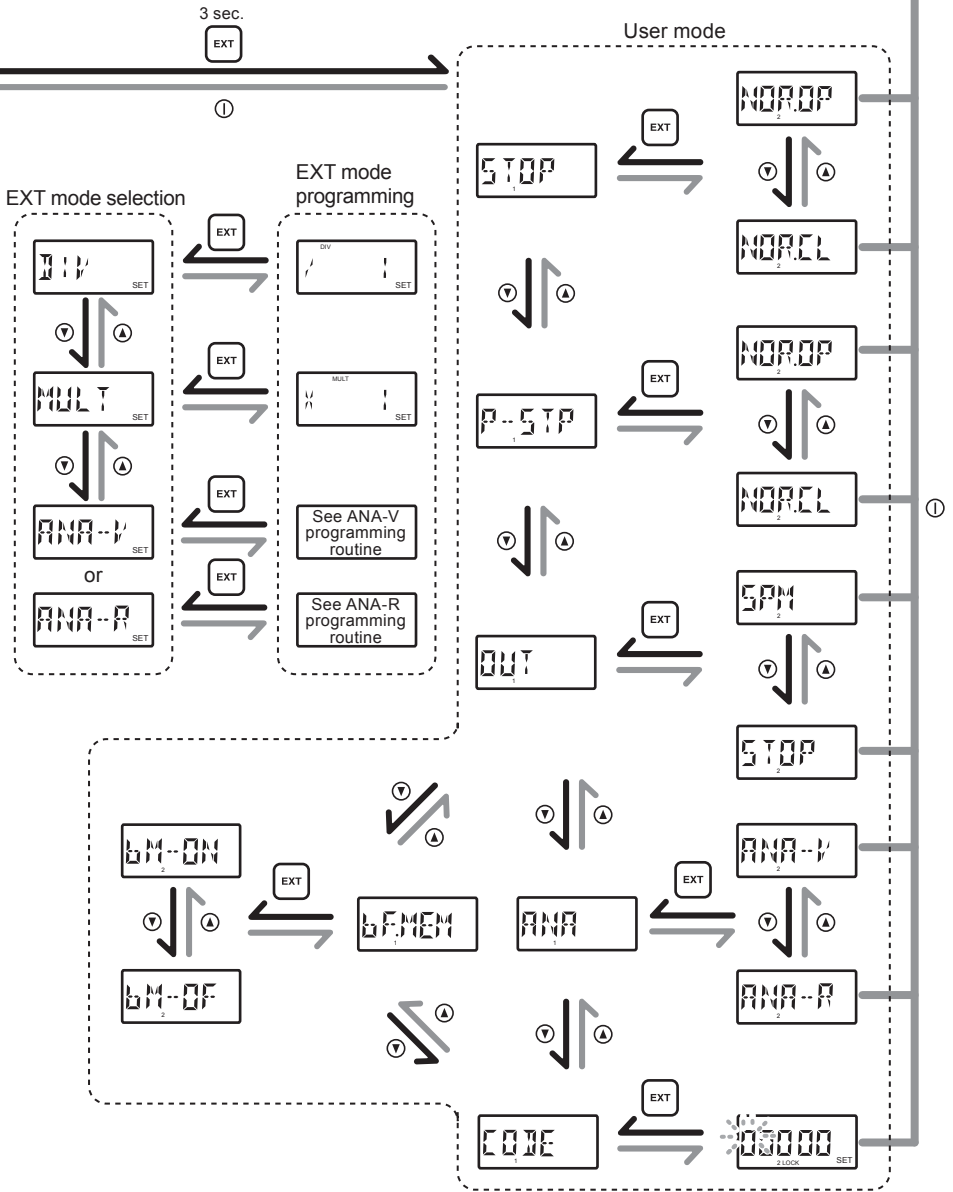

Operation

## 1 Turn on power.

The LED lights and a display related to the current mode appears on the screen.

\*The pump enters the wait state in the manual mode when turning on power with a default setting. The pump calls up the last screen at a shutoff if it was not in a default setting.



## 2 Enter manual mode.

Move to the next step when the stroke rate (0.1-100%) is shown on the screen.

**When "MULT", "DIV", "ANA-R" or "ANA-V" is on the screen...**

Push the start/stop key once to enter the wait state in the manual mode.

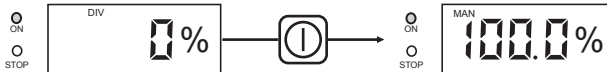

**When "STOP" or "-STOP" is on the screen...**

See "STOP function cancellation" on page 62 and release the function.

## 3 Use the UP or DOWN key to adjust stroke rate.

- A stroke rate increases/decreases as pushing the UP/DOWN keys.
- Press and hold either key for three seconds for quick change. Quick change stops at 0.1 or 100%. 0.1 or 100% skips to 100 or 0.1% when the key is released and pushed again.

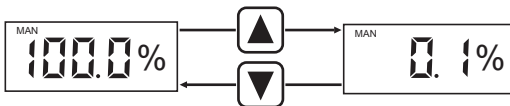

## 4 Push the start/stop key.

The pump starts to run.

- The LED starts to blink at each shot.

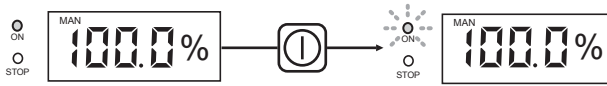

## EXT operation

The pump operation is controlled by the external (pulse) signal.

### ■ EXT mode

Set the upper limit spm and enter EXT mode. Note that the pump starts to run in sync with the external signal as entering EXT mode.

### NOTE

- Manual operation stroke rate is applied as the EXT upper limit spm. For example, even if the external signal is entered to run the pump at 100% (360spm), the pump does not run over 50% (180spm) as long as manual stroke rate is 50%.
- A stroke rate skips from 100 to 0.1% by pushing the UP key once. Pay attention to this point when programming a stroke rate for the prevention of an erroneous programming.

## 1 Enter manual mode.

Enter the manual mode to indicate a stroke rate on the screen.

- Push the start/stop key when "MULT", "DIV", "ANA-R" or "ANA-V" is on the screen.
- When "STOP" or "-STOP" appears on the screen, see "STOP function cancellation" on 62 page and release the STOP function.



## 2 Use the UP or DOWN key to program the upper limit.

Push the start/stop key and stop the pump when the pump is running. Then program stroke rate.

- A stroke rate increases/decreases as pushing the UP/DOWN keys.
- Press and hold either key for three seconds for quick change. Quick change stops at 0.1 or 100%. 0.1 or 100% skips to 100 or 0.1% when the key is released and pushed again.

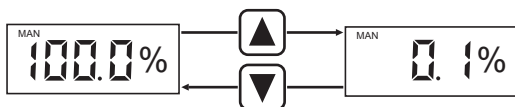

## 3 Push the EXT key to enter EXT mode.

Note that the pump starts to run in sync with the external signal as entering EXT mode.

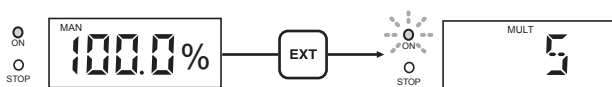

### ■ EXT mode programming

The following features can be programmed for the EXT operation.

#### • Multiplier programming

The number of shots per signal is programmed. A default setting is one shot per signal.

#### • Divider programming

The number of signals per shot is programmed. A default setting is one shot per signal.

#### • Analogue programming

Current values are programmed for a proportional control.

### NOTE

Pushing the start/stop key, a program is entered. Do not forget to enter your programming. Note if the pump is unplugged before pushing the start/stop key, your programming is not stored.

## Multiplier programming

Program the number of shots per signal to control the pump. The number of shots can be programmed from 1 to 9999.

### NOTE

Do not enter the external signal during programming.

#### 1 Enter EXT mode.

Push the EXT key to move from manual mode to EXT mode.

\*Push the start/stop key and stop the pump when the pump is running. Then call up EXT mode.

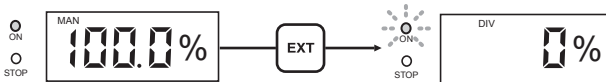

#### 2 Press and hold the EXT key for one second and enter the EXT mode selection.

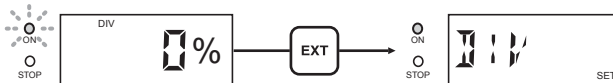

#### 3 Select "MULT" (Multiply).

Scroll through the EXT mode selection by the UP and DOWN keys.

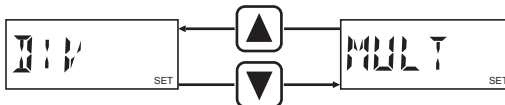

#### 4 Push the EXT key and call up the multiplier programming screen.

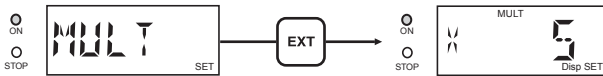

#### 5 Use the UP or DOWN key to program a multiplier.

- A multiplier increases/decreases as pushing the UP/DOWN keys.
- Press and hold either key for three seconds for quick change. Quick change stops at 1 or 9999. 1 or 9999 skips to 9999 or 1 when the key is released and pushed again.

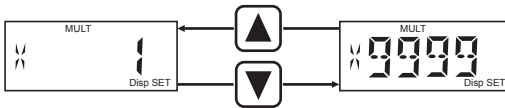

#### 6 Push the EXT key to return to the EXT mode selection.

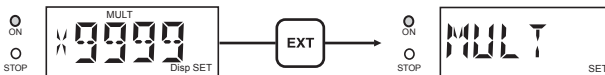

#### 7 Push the start/stop key to return to EXT mode.

The pump starts to run according to the multiplier programming.

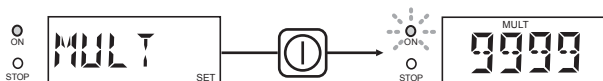

## Divider programming

Program the number of signals per shot to control the pump. The number of signals can be programmed from 1 to 9999.

### NOTE

- If a divider is programmed to 1 to make 1:1 operation and the input interval of the external signal is close to a manual operation stroke rate (but not exactly in synchronization), irregular operation may occur. This irregular operation occurs as the external signal is cancelled. Note that this is not malfunction. In order to avoid this phenomenon, perform 1:1 operation by programming a multiplier to 1.
- Do not enter the external signal during the programming.

### 1 Enter EXT mode.

Push the EXT key to move from manual mode to EXT mode.

\*Push the start/stop key and stop the pump when the pump is running. Then call up EXT mode.

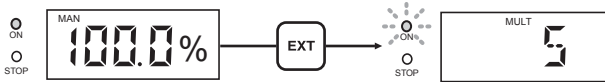

### 2 Press and hold the EXT key for one second and enter the EXT mode selection.

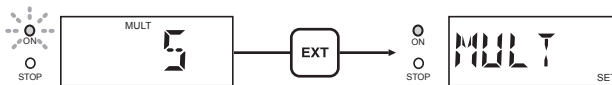

### 3 Select "DIV" (Divide).

Scroll through the EXT mode selection by the UP and DOWN keys.

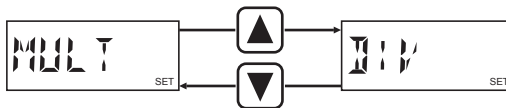

#### 4 Push the EXT key and call up the multiplier programming screen.

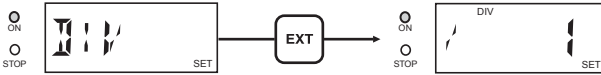

#### 5 Use the UP or DOWN key to program a divider.

- A divider increases/decreases as pushing the UP/DOWN keys.
- Press and hold either key for more than three seconds for quick change. Quick change stops at 1 or 9999. 1 or 9999 skips to 9999 or 1 when the key is released and pushed again.

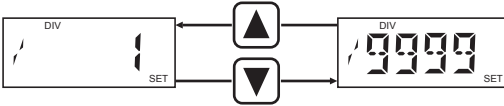

#### 6 Push the EXT key to return to the EXT mode selection.

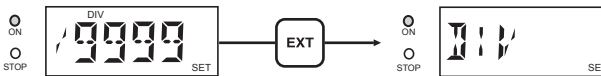

#### 7 Push the start/stop key to return to EXT mode.

The pump starts to run according to the multiplier programming.

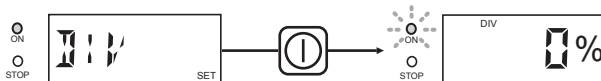

Flow rate display changes every time the Disp key is pressed.

# ANA-V programming

Select "ANA-V" or "ANA-R" in USER mode. See page 66.

## 1 Enter EXT mode.

Push the EXT key to move from manual mode to EXT mode.

\*Push the start/stop key and stop the pump when the pump is running. Then call up EXT mode.

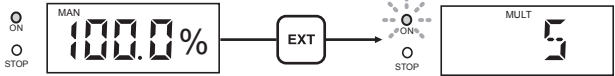

## 2 Press and hold the EXT key for one second and enter the EXT mode selection.

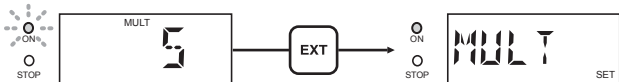

## 3 Select "ANA-V" (Analogue variable).

Scroll through the EXT mode selection by the UP and DOWN keys.

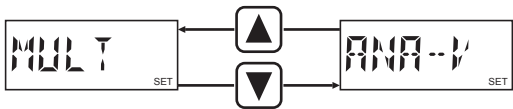

## 4 Push the EXT key and enter a current value at P1.

- A current value increases/decreases as pushing the UP/DOWN keys.
- Press and hold either key for three seconds for quick change. Quick change stops at 0.0 or 20.0mA. 0.0 or 20.0mA skips to 20.0 or 0.0mA when the key is released and pushed again.

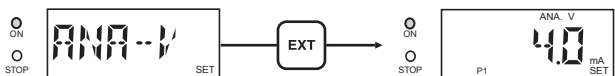

## 5 Push the Disp key and enter a stroke rate at P1.

- A stroke rate increases/decreases as pushing the UP/DOWN keys.
- Press and hold either key for three seconds for quick change. Quick change stops at 0 or 100%. 0 or 100% skips to 100 or 0% when the key is released and pushed again.

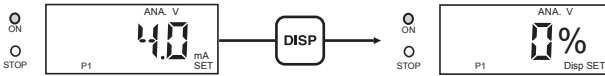

## 6 Push the Disp key and enter a current value at P2.

- A current value increases/decreases as pushing the UP/DOWN keys.
- Press and hold either key for three seconds for quick change. Quick change stops at 0.0 or 20.0mA. 0.0 or 20.0mA skips to 20.0 or 0.0mA when the key is released and pushed again.

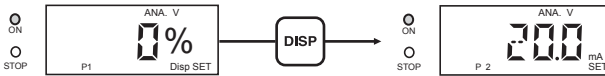

## 7 Push the Disp key and enter a stroke rate at P2.

- A stroke rate increases/decreases as pushing the UP/DOWN keys.
- Press and hold either key for three seconds for quick change. Quick change stops at 0 or 100%. 0 or 100% skips to 100 or 0% when the key is released and pushed again.

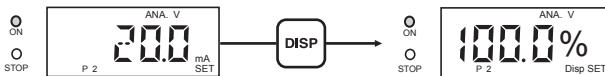

## 8 Push the EXT key to return to the EXT mode selection.

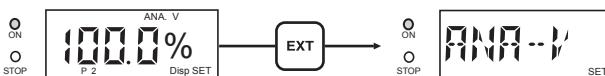

## 9 Push the start/stop key to return to EXT mode.

The pump starts to run in proportional control according to the ANA-V programming.

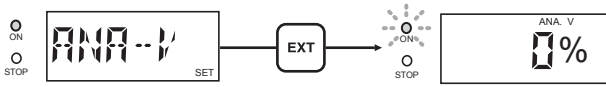

## ANA-R programming

Select "ANA-V" or "ANA-R" in USER mode. See page 66.

### 1 Enter EXT mode.

Push the EXT key to move from manual mode to EXT mode.

\*Push the start/stop key and stop the pump when the pump is running. Then call up EXT mode.

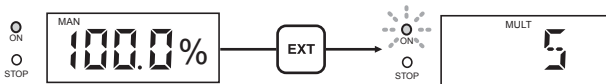

### 2 Press and hold the EXT key for one second and enter the EXT mode selection.

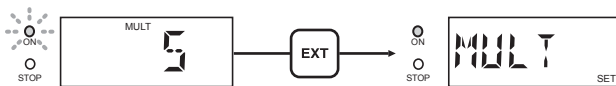

### 3 Select "ANA-R" (Analogue rigid).

Scroll through the EXT mode selection by the UP and DOWN keys.

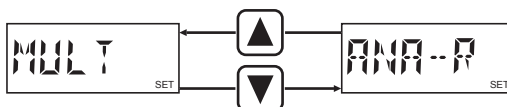

#### 4 Push the EXT key and select a preset program.

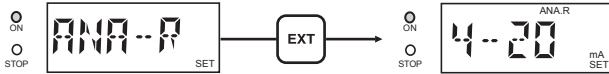

Scroll through the ANA-R programming routine by the UP and DOWN keys.

#### 5 Push the EXT key to return to the EXT mode selection.

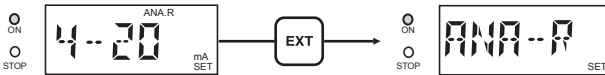

#### 6 Push the start/stop key to enter EXT mode.

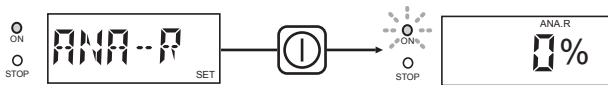

The pump starts to run in proportional control according to the ANA-R programming.

## User mode

The following features can be programmed. Get access to User mode via the wait state in the manual mode.

- **STOP function**

The pump stops running while receiving the external signal via the STOP terminal.

- **Pre-STOP function**

The STOP LED lights orange while the pump receiving the external signal via the Pre-STOP terminal. The pump does not stop running.

- **OUTPUT function**

The pump sends out signals via the OUTPUT terminal in sync with pump shots or the STOP signal.

- **ANA-V/-R selection**

Select either "ANA-V" or "ANA-R" for the EXT mode.

- **Buffer ON/OFF selection**

Excessive external signals that are not reflected to the MULT or DIV operation can be stored. Activate or inactivate the buffer.

- **PIN number entry**

A PIN is required to release a keypad lock state.

### NOTE

The ANA-V/-R selection is available only when "ANA-V" or "ANA-R" has been selected in the EXT mode selection. The Buffer ON/OFF selection is available only when "DIV" or "MULT" has been selected.

#### EXT mode selection

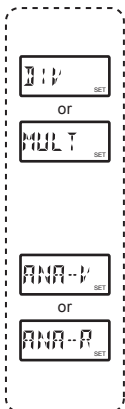

#### User mode

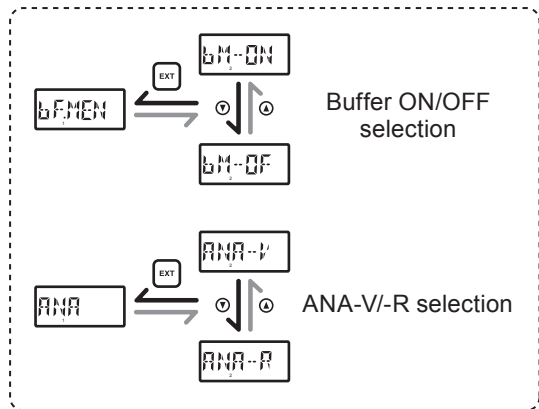

## ■ STOP/Pre-STOP function

The start/stop of the pump operation can be controlled by the external stop signal.

### • When "NOR. OP" is selected...

The pump stops while receiving the stop signal.

### • When "NOR. CL" is selected...

The pump runs while receiving the stop signal.

## STOP/Pre-STOP function programming

### 1 Return to the wait state in the manual mode.

Push the start/stop key to return to the manual wait state if the pump is running in manual mode or in EXT mode.



### 2 Push the EXT key for three seconds to call up the user mode.

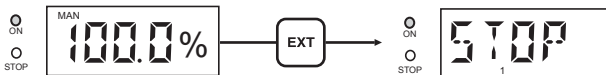

### 3 Select "STOP" or "P-STP".

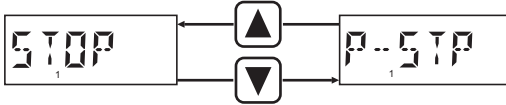

Scroll through the User mode selection by the UP and DOWN keys.

### 4 Push the EXT key.

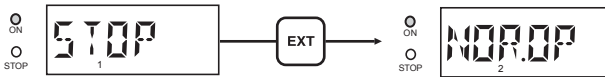

### 5 Select "NOR. OP" or "NOR. CL".

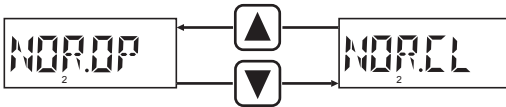

### 6 Push the start/stop key to return to manual mode.

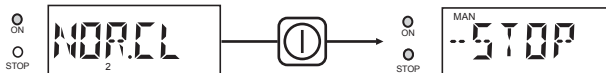

The screen indicates that the STOP function is active.

## ■ STOP/Pre-STOP function cancellation

A stop state can be cancelled if the current selection is changed.

Example) NOR.OP→NOR.CL  
NOR.CL→NOR.OP

### 1 Call up "-STOP" screen.

If the screen shows "STOP" in the manual or EXT mode, push the start/stop key.



### 2 Press and hold the EXT key for three seconds to enter User mode.



### 3 Select "STOP" or "P-STP".

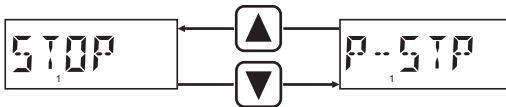

Scroll through the User mode selection by the UP and DOWN keys.

#### 4 Push the EXT key and change the current selection.

If "NOR.OP" is selected change it to "NOR.CL", and vice versa.



#### 5 Push the start/stop key to return to manual mode.

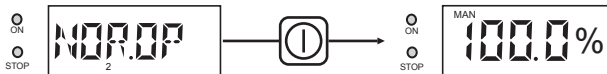

The STOP or Pre-STOP function now has been cancelled.

## ■ OUTPUT function

### • When "OUT"→"SPM" is selected...

The pump sends the OUTPUT signal at each shot while running.

### • When "OUT"→"STOP" is selected...

- The pump sends the OUTPUT signal while receiving the STOP signal (with the setting of operation stop at STOP signal input).
- The pump sends the OUTPUT signal while receiving no STOP signal (with the setting of operation resumption at STOP signal input).

## 1 Return to the wait state in the manual mode.

Push the start/stop key to return to the manual wait state if the pump is running in manual mode or in EXT mode.



## 2 Push the EXT key for three seconds to call up the user mode.

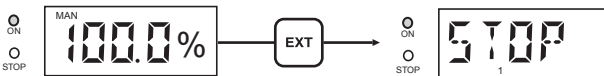

## 3 Select "OUT".

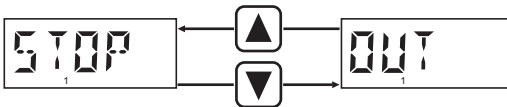

Scroll through the User mode selection by the UP and DOWN keys.

#### 4 Push the EXT key.

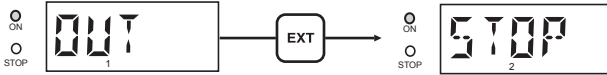

#### 5 Select "STOP" or "SPM".

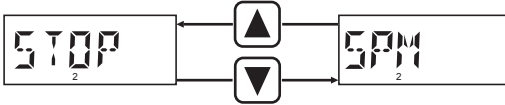

#### 6 Push the start/stop key to return to manual mode.

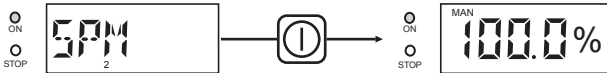

The programming has now been reflected to the pump operation.

## ■ ANA-V/-R selection

### • When "ANA-R" is selected...

The preset proportional control programs of "4-20", "20-4", "0-20" and "20-0" are available.

### • When "ANA-V" is selected...

A proportional control pattern can be newly programmed.

#### NOTE

A default setting is "ANA-R".

## 1 Return to the wait state in the manual mode.

Push the start/stop key to return to the manual wait state if the pump is running in manual mode or in EXT mode.



## 2 Push the EXT key for three seconds to call up the user mode.

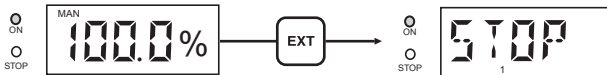

## 3 Select "ANA".

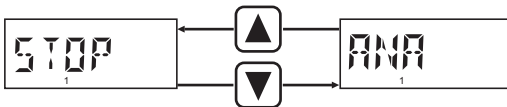

Scroll through the User mode selection by the UP and DOWN keys.

#### 4 Push the EXT key.

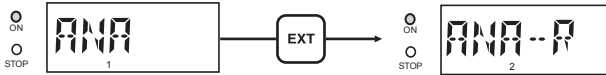

#### 5 Select "ANA-R" or "ANA-V".

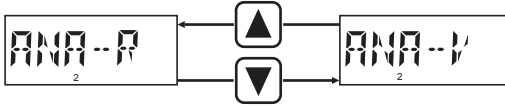

#### 6 Push the start/stop key to return to manual mode.

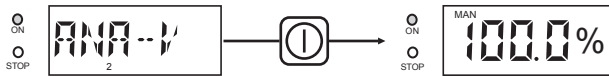

The programming has now been reflected to the pump operation.

■ **Buffer ON/OFF selection**

• **When "bM-ON" is selected...**

Excessive external signals that are not reflected to the MULT or DIV operation can be stored.

• **When "bM-OFF" is selected...**

Excessive external signals are not stored.

NOTE

A default setting is "bM-OFF".

**1 Return to the wait state in the manual mode.**

Push the start/stop key to return to the manual wait state if the pump is running in manual mode or in EXT mode.



**2 Push the EXT key for three seconds to call up the user mode.**

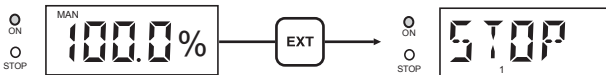

**3 Select "bF.MEM".**

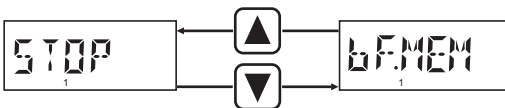

Scroll through the User mode selection by the UP and DOWN keys.

#### 4 Push the EXT key.

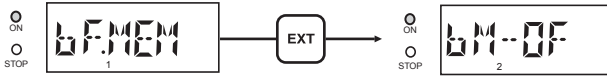

#### 5 Select "bM-ON" or "bM-OF".

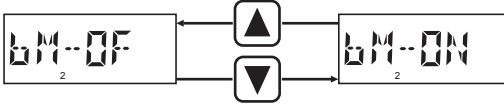

#### 6 Push the start/stop key to return to manual mode.



The programming has now been reflected to the pump operation.

\*The pump can run up to 65535 shots by the stored excessive signals.

## ■ PIN number entry

A PIN is required to release a keypad lock state.

NOTE

A default setting is "bM-OF".

### 1 Return to the wait state in the manual mode.

Push the start/stop key to return to the manual wait state if the pump is running in manual mode or in EXT mode.



### 2 Push the EXT key for three seconds to call up the user mode.

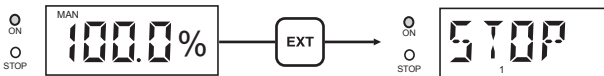

### 3 Select "CODE".

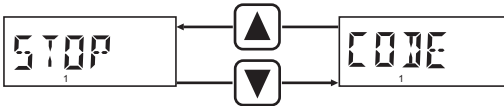

Scroll through the User mode selection by the UP and DOWN keys.

#### 4 Push the EXT key.

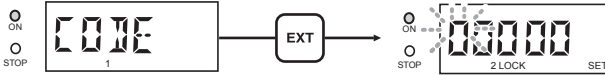

#### 5 Use the UP and DOWN keys to create PIN number.

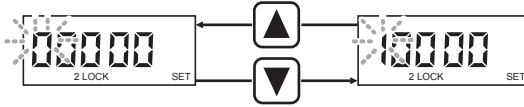

Shift to the next digit by pushing the DISP key.

\*A default PIN number is "00000".

#### 6 Push the start/stop key to return to manual mode.

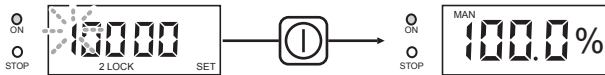

The programming has now been entered.

\*Pushing the EXT key, the programming is cancelled.

## Keypad lock

---

Keypad lock can be active in the following states for the prevention of erroneous key operation.

### Manual mode

Wait state



During operation



### EXT mode

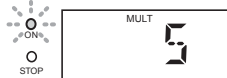

### NOTE

---

- Any key operation is not acceptable when the keypad lock is active. In an emergency, unplug the pump or enter the external signal via the STOP terminal to stop operation. If the pump is unplugged, a keypad lock state is recalled when the pump is turned on.
  - Pressing the start/stop key for three seconds, keypad lock becomes active even when the pump is receiving the STOP signal. Note that "STOP" or "-STOP" indication does not change but key operation is not accepted. Keypad lock indication appears when the STOP signal is released with "M-ON" or inputted with "M-OFF".
-

## ■ Keypad lock activation

1 Press and hold the start/stop key for more than three seconds.

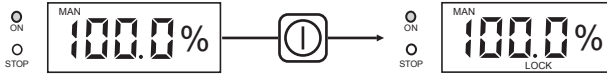

"LOCK" indication appears on the screen.

## ■ Keypad lock release

1 Push the EXT key once.

Enter the PIN number.

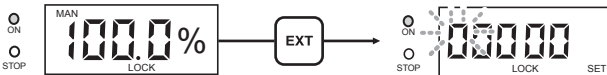

Shift to the next digit by pushing the DISP key.

\*A default PIN number is "00000".

2 Push the EXT key once again.

The keypad lock state is released.

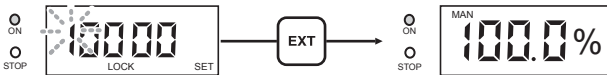

3 Pause/Resume operation

- To stop the pump in the keypad lock state, press and hold the start/stop key for three seconds.
- To resume operation in the keypad lock state, push the start/stop key once.

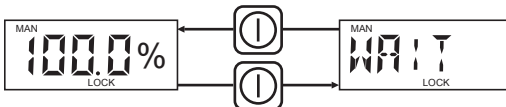

## Calibration mode

Entering a flow rate per shot, the flow rate can be checked in GPH, L/h or mL/m.

- 1 Run the pump in an actual operating condition and measure the flow for one minute.

- 2 Return to the wait state in the manual mode.

Push the start/stop key to return to the manual wait state if the pump is running in manual mode or in EXT mode.



- 3 Press and hold the DISP key for three seconds to call up the calibration mode.

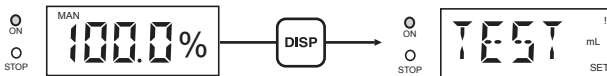

- 4 Push the DISP key once to call up a flow entry screen.

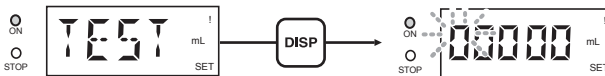

## 5 Enter the measured flow.

Shift to the next digit by pushing the DISP key.

\*Pushing the EXT key, the programming is cancelled.

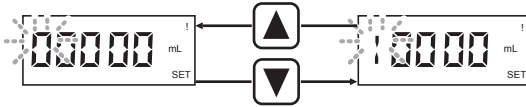

## 6 Push the start stop key to return to the wait state.

The programming is stored as "SAVE" indication appears on the screen. The maximum flow can be checked at each unit.

\*Always try to change the flow rate by stroke rate. Changing the stroke length, the flow rate per shot is changed.

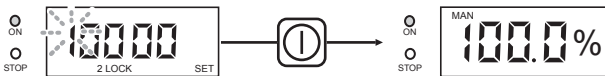

## Unit change

GPH, L/h or mL/m cycles through every time the DISP key is pushed. To display the maximum flow rate at each unit, follow the above calibration procedure.

## spm indication

The screen shows an actual spm in operation when both the EXT and DOWN keys are pressed for 3 seconds. 0spm will be shown after the pump has stopped.

Before shipping, every pump is regulated by spm adjustment so as to meet a required flow rate at 100% stroke rate indication. Note that spm at the same stroke rate (%) may differ at each pump accordingly.

# Maintenance

*This section describes troubleshooting, inspection, wear part replacement, exploded views and specifications.*

## **!** Important

- Observe instructions in this manual for maintenance, inspection, dismantlement and assembly. Do not dismantle the pump beyond the extent of the instructions.
- Always wear protective clothing such as an eye protection, chemical resistant gloves, a mask and a work cap during dismantlement, assembly or maintenance work.
- Be sure to turn off power to stop the pump and related devices before work. See below.

## **Before unplugging the pump**

Always stop the pump by key operation. And wait for three seconds before unplugging the pump. Otherwise, the last key operation to stop the pump may not be put in memory. In this case the pump unintentionally starts to run as powered on, discharging liquid.

---

## NOTE

- We do not assure material suitability in a specified application and are not responsible for any failure due to corrosion or erosion.
  - Contact us or your nearest dealer for repair or contact a manufacturer of the host machine which our product is built in.
  - Be sure to drain chemicals and clean the inside of the pump before return so that a harmful chemical does not spill out in transit.
-

## Troubleshooting

First check the following points. If the following measures do not help remove problems, contact us or your nearest dealer.

States	Possible causes	Solutions
The pump does not run. (LED does not appear. Blank screen.)	Power voltage is too low.	<ul style="list-style-type: none"> <li>Recover the power voltage to a normal level.</li> <li>Allowable voltage range: 90-264VAC</li> </ul>
	The pump is not powered.	<ul style="list-style-type: none"> <li>Check the switch if it is installed.</li> <li>Correct wiring.</li> <li>Replace a breaking wire to new one.</li> </ul>
Liquid can not be sucked up.	Air lock in the pump	<ul style="list-style-type: none"> <li>Expel air. See page 38.</li> </ul>
	Stroke length is too short.	<ul style="list-style-type: none"> <li>Run the pump at 100% stroke length and adjust it to proper length.</li> </ul>
	Air ingress through suction line.	<ul style="list-style-type: none"> <li>Correct tubing.</li> </ul>
	A valve set is installed upside down.	<ul style="list-style-type: none"> <li>Reinstall the valve set.</li> </ul>
	Valve gaskets are not installed.	<ul style="list-style-type: none"> <li>Install valve gaskets.</li> </ul>
	Foreign matters are stuck in the pump head valves.	<ul style="list-style-type: none"> <li>Dismantle, inspect and clean the valve. Replace as necessary.</li> </ul>
	A ball valve is stuck on a valve seat.	<ul style="list-style-type: none"> <li>Dismantle, inspect and clean the valve. Replace as necessary.</li> </ul>
The flow rate fluctuates.	Air stays in the pump head.	<ul style="list-style-type: none"> <li>Expel air. See page 38.</li> </ul>
	Overfeeding occurs.	<ul style="list-style-type: none"> <li>Mount a check valve. See page 28.</li> </ul>
	Foreign matters are stuck in the pump head valves.	<ul style="list-style-type: none"> <li>Dismantle, inspect and clean the valve. Replace as necessary.</li> </ul>
	Diaphragm is broken.	<ul style="list-style-type: none"> <li>Replace diaphragm.</li> </ul>
	Pressure fluctuates at an injection point.	<ul style="list-style-type: none"> <li>Review tubing layout to maintain a pressure constant at an injection point or change an injection point in a constant pressure.</li> </ul>

States	Possible causes	Solutions
Liquid leaks.	Loose fit of the fitting or the air vent body	• Retighten them.
	Loose fit of the pump head	• Retighten the pump head. See page 37.
	O rings or valve gaskets are not installed.	• Install O rings and valve gaskets.
	Diaphragm is broken.	• Replace the diaphragm.
	Excessive discharge pressure	• Check that a discharge line is not closed. • Check if tubing is not clogged.
Key operation is ineffective.	Keypads are locked.	• Release the keypad lock.
The pump does not run.	The pump is in a wait state.	• Enter the pump into an operation mode.
	The pump has not received the external signal in the EXT mode.	• Check wiring.
	EXT mode programming has not finished.	• Complete EXT mode programming.
The pump does not receive the external signal.	The signal has not been sent to the pump.	• Check wiring.
The pump does not store EXT mode programming.	EXT mode programming has not been stored to the pump.	• Push the start/stop key after programming.

## Inspection

Perform daily inspection and periodic inspection to keep pump performance and safety.

### Daily inspection

Check the following points. Upon sensing abnormal condition, stop operation immediately and remove problems according to "Troubleshooting".

When wear parts come to the life limit, replace them by new ones. Contact us or your nearest dealer for detail.

No.	States	Points to be checked	How to check
1	Pumping	• If liquid is pumped.	Flow meter or visual inspection
		• If the suction and discharge pressure are normal.	Check specification.
		• If liquid is deteriorated, crystallized or settled.	Visual or audio inspection
2	Noise and vibration	• If abnormal noise or vibration occurs. They are signs of abnormal operation.	Visual or audio inspection
3	Air ingress from pump head joints and a suction line	• If leakage occurs. • If discharge liquid includes air bubbles, check lines for leakage and retighten as necessary.	Visual or audio inspection

### Periodic inspection

Retighten the pump head mounting bolts diagonally according to the following torque.

\*Mounting bolts may loosen in operation. How fast the bolts start to loosen is depending on operating conditions.

#### Tightening torque

Model identification code	Torque	Bolts
EWN-B09•11•16•21	2.16 N•m	M4 Hex. socket head bolt
EWN-B31	2.55 N•m	M4 Hex. socket head bolt
EWN-C16•21	2.16 N•m	M4 Hex. socket head bolt
EWN-C31	2.55 N•m	M4 Hex. socket head bolt
EWN-C36	2.55 N•m	M5 Hex. socket head bolt

\*A hexagon wrench can be used for a torque wrench. See page 38.

# Wear part replacement

For a long operation wear parts need to be replaced periodically.

It is recommended that the following parts are always stocked for immediate replacement. Contact us or your nearest dealer for detail.

## ! Precautions

- When dismantling the pump, pay attention to the residual liquid in the pump.
- Rinse wet ends thoroughly with water.
- Each time the pump head is dismantled, replace the diaphragm, O rings, valve gaskets and valve sets with new ones.

## Wear part list

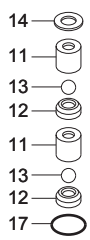
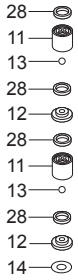
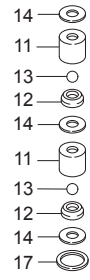
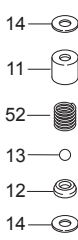
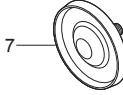
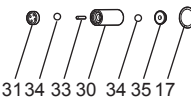
		Parts				# of parts	Estimated life
Pump	Valve set	VC•VH•PC•PH•TC 	SH 	FC 	PC/P6 	2 sets	8000 hours
	Diaphragm					1	
	Automatic air vent valve set					1	

\*The high pressure types have a rear diaphragm sheet on the back side of the diaphragm.

\*Wear part duration varies with the pressure, temperature and characteristics of the liquid.

\*The estimated life is calculated based on the continuous operation with ambient clean water.

## ***Before replacement***

---

*First release the pressure from the pump.*

**1 Stop the pump operation.**

**2 Rotate the adjusting screw two revolutions anticlockwise to open the air vent port.**

**NOTE**

Do not rotate it three revolutions or more. Otherwise, liquid may come out from the adjusting screw.

**3 Check that liquid comes out from the air vent port and the internal pressure has been released.**

**NOTE**

The internal pressure may not be expelled completely as long as liquid does not come out. In this case run the pump until the pressure is released.

\*The air vent port is not equipped to the FC. Install an air vent valve on a discharge line and release the pressure by opening the valve. See page 27.

## ***Valve set replacement***

---

### **■ Discharge valve set dismantlement/assembly**

#### **Necessary tools**

- Adjustable wrench or spanner
- 21mm box wrench
- A pair of tweezers

\*Unfix the pump base before work.

- 1 Loosen the fitting nut and remove a discharge tube and an air bleed tube.

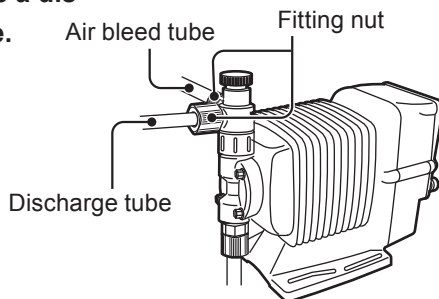

- 2 Turn the lock nut anticlockwise by an adjustable wrench and remove the air vent body A.

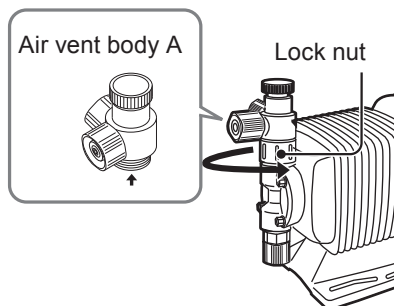

- 3 Remove the air vent body B by the 21mm box wrench.

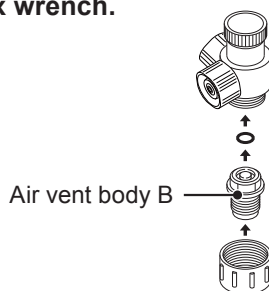

- 4 Pull out the valve set by a pair of tweezers.

**5 Place a new valve set into the pump head.  
Screw the air vent body B into the pump head through the lock nut.**

- \*Be careful not to misarrange the valve set or place it upside down. Otherwise, leakage or flow rate reduction may result.
- \*Do not forget to fit O rings and gaskets.
- \*Keep the valve set free from dust or foreign matters.

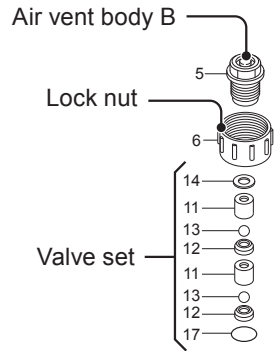

\*VC•VH•PC•PH

**6 Remount the air vent body A and connect tubes.**

■ **Suction valve set dismantlement/assembly**

NOTE

Be careful not to drop the valve set.

**1 Remove the fitting nut to remove the suction tube.**

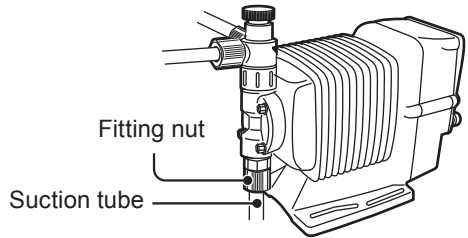

**2 Remove the fitting by an adjustable wrench or a spanner.**

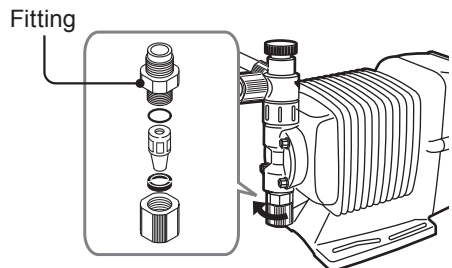

**3 Pull out the valve set by a pair of tweezers.**

**4 Screw the fitting into the pump head with the valve set in it and turn it anticlockwise about 90 degrees by an adjustable wrench or a spanner.**

- \*Be careful not to misarrange the valve set or place it upside down. Otherwise, leakage or flow rate reduction may result.
- \*Do not forget to fit O rings and gaskets.
- \*Keep the valve set free from dust or foreign matters.

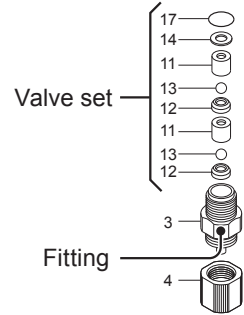

\*VC•VH•PC•PH•TC

**5 Reconnect the suction tube.**

#### ■ Spacer set replacement (Automatic air vent type)

Dismantlement/assembly of the discharge and suction valve sets are the same. See page 81-83 for detail.

**1 Loosen the lock nut and remove the fitting adapter.**

**2 Loosen the air vent body B and take it out of the pump head. Then pull out the spacer set.**

**3 Place a new spacer set into the pump head. Screw the air vent body B into the pump head through the lock nut.**

- \*Do not forget to fit O rings and gaskets.
- \*Keep the spacer set free from dust or foreign matters.

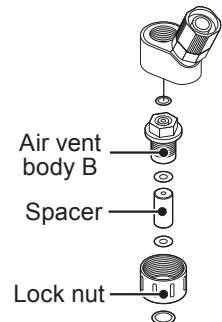

## ■ Air vent valve set replacement (Automatic air vent type)

### 1 Loosen the fitting nut and remove an air bleed tube.

\*Be careful not to get wet with a residual chemical.

### 2 Loosen and remove the fitting.

### 3 Take the air vent valve set out of the fitting adapter.

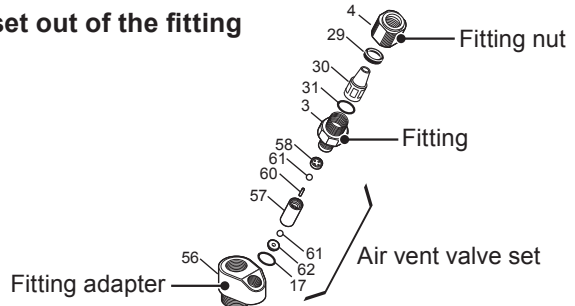

### 4 Place a new air vent valve set into the fitting and then screw it into the fitting adapter as far as it will go. Turn the fitting further 90 degrees clockwise with a spanner.

\*Note the air vent valve set has a mounting direction.

Always mount the depressed end first.

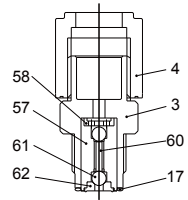

## *Diaphragm replacement*

### Necessary tools

- Adjustable wrench or spanner
- Hexagon wrench
- Torque wrench

### NOTE

Pay attention not to lose diaphragm spacers. Always apply a proper number of diaphragm spacers. 0 or a few diaphragm spacers are inserted between the retainer and plunger for the adjustment of diaphragm location. Note that the number of diaphragm spacers varies with pump model. Some pumps may use no spacer.

**1 Run the pump and set the stroke length to 0%. Then stop the pump.**

**2 Loosen the fitting nuts and remove a suction tube, a discharge tube and an air bleed tube.**

For the automatic air vent type, disconnect another air bleed tube from the automatic air vent valve body as well.

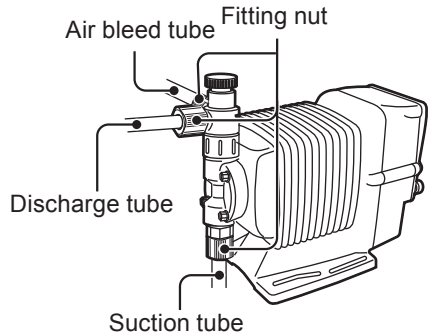

**3 Remove the pump head by a hexagon wrench.**

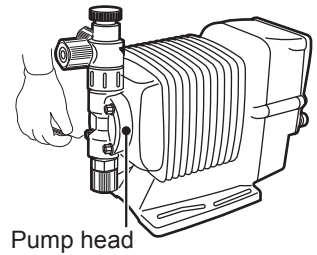

**4 Rotate and remove the diaphragm from the plunger (pump shaft).**

**5 Set a retainer and diaphragm spacer(s) on the diaphragm screw.**

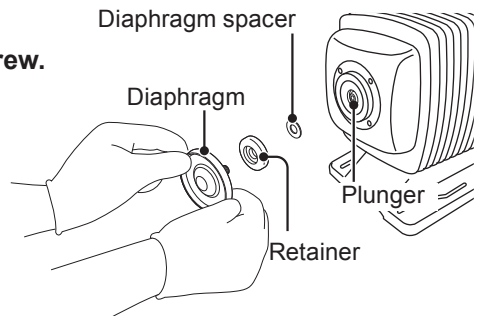

## NOTE

- Fit the retainer to the diaphragm with its round edge to the diaphragm.
- Check that the bracket spacer is in place. Refit the bracket spacer into the bracket, combining mating parts as necessary.
- The B/C-31 & -36 types do not have a bracket spacer.

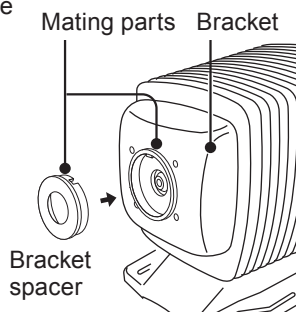

**6** Screw the diaphragm all the way seated in the plunger.

**7** Run the pump and set the stroke length to 100%. Then stop the pump.

**8** Mount the pump head.

Tighten the pump head fixing bolts diagonally and evenly.

### Tightening torque

Model identification code	Torque	Bolts
EWN-B09•11•16•21	2.16 N•m	M4 Hex. socket head bolt
EWN-B31	2.55 N•m	M4 Hex. socket head bolt
EWN-C16•21	2.16 N•m	M4 Hex. socket head bolt
EWN-C31	2.55 N•m	M4 Hex. socket head bolt
EWN-C36	2.55 N•m	M5 Hex. socket head bolt

\*A hexagon wrench can be used for a torque wrench. See page 38.

# Exploded view

## Pump head, Drive unit & Control unit

The pump in the diagram below is completely dismantled. Do not dismantle the pump beyond the extent shown in this instruction manual.

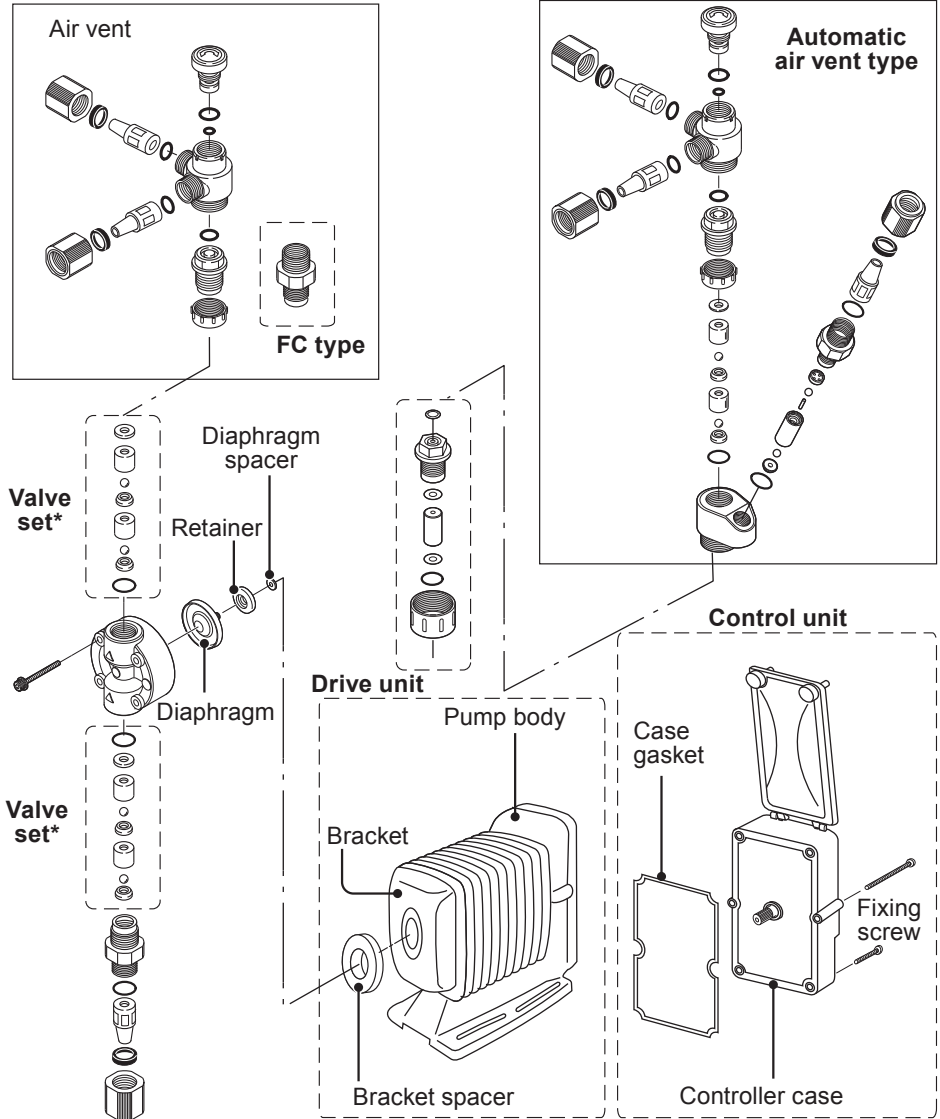

\*Wet end materials and their sizes differ with models. See "Valve set replacement" on page 81 for detail.

# Pump head

■ EWN-[B09•B11•B16•B21•C16•C21][VC•VH•PC•PH•TC]

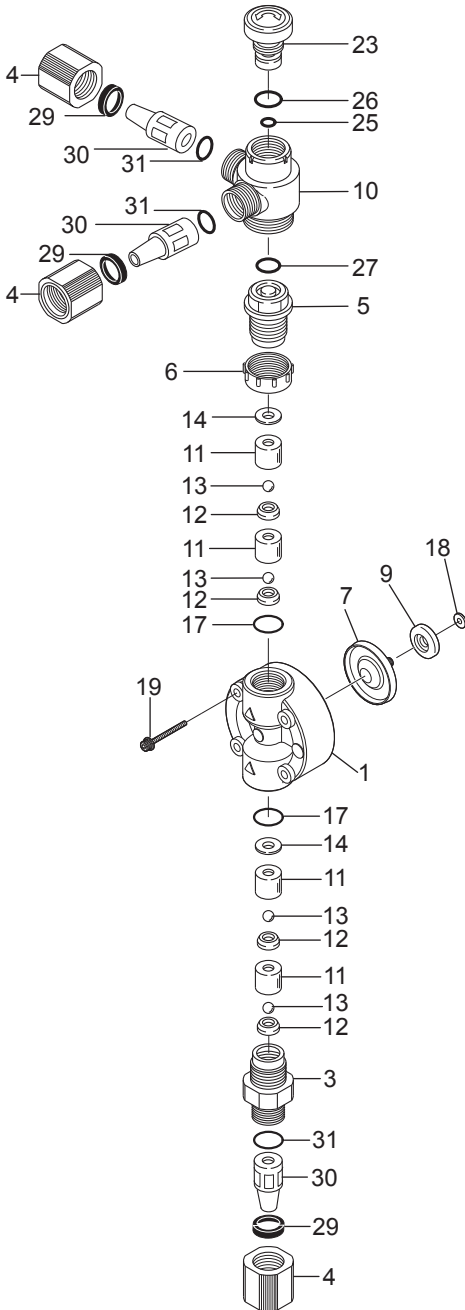

No.	Part names	# of parts
1	Pump head	1
3	Fitting	1
4	Fitting nut	3
5	Air vent body B	1
6	Lock nut	1
7	Diaphragm	1
9	Retainer	1
10	Air vent body A	1
11	Valve guide	4
12	Valve seat	4
13	Valve	4
14	Valve gasket	2
17	O ring	2
18	Diaphragm spacer	*
19	Hex. socket head bolt [PW•SW]	4
23	Adjusting screw	1
25	O ring	1
26	O ring	1
27	O ring	1
29	Hose stopper	3
30	Hose adaptor	3
31	O ring	3

\*The number of diaphragm spacers varies with pump model.

\*For the high pressure types, a rear diaphragm sheet is placed between the parts 7 and 9.

■ EWN-[B31•C31•C36][VC•VH•PC•PH•TC]

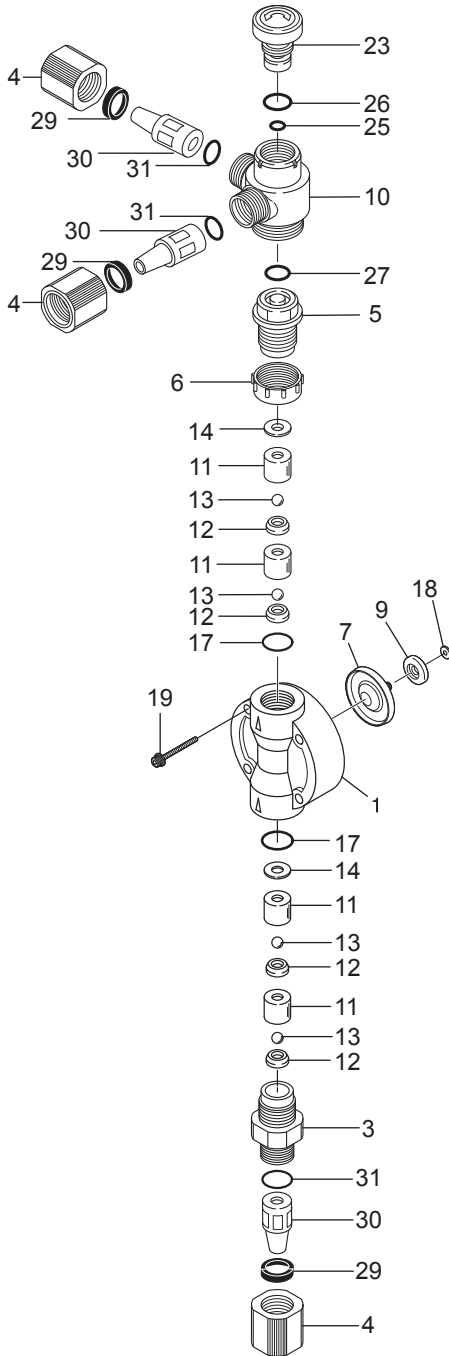

No.	Part names	# of parts
1	Pump head	1
3	Fitting	1
4	Fitting nut	3
5	Air vent body B	1
6	Lock nut	1
7	Diaphragm	1
9	Retainer	1
10	Air vent body A	1
11	Valve guide	4
12	Valve seat	4
13	Valve	4
14	Valve gasket	2
17	O ring	2
18	Diaphragm spacer	*
19	Hex. socket head bolt [PW•SW]	4
23	Adjusting screw	1
25	O ring	1
26	O ring	1
27	O ring	1
29	Hose stopper	3
30	Hose adaptor	3
31	O ring	3

\*The number of diaphragm spacers varies with pump model.

\*For the high pressure types, a rear diaphragm sheet is placed between the parts 7 and 9.

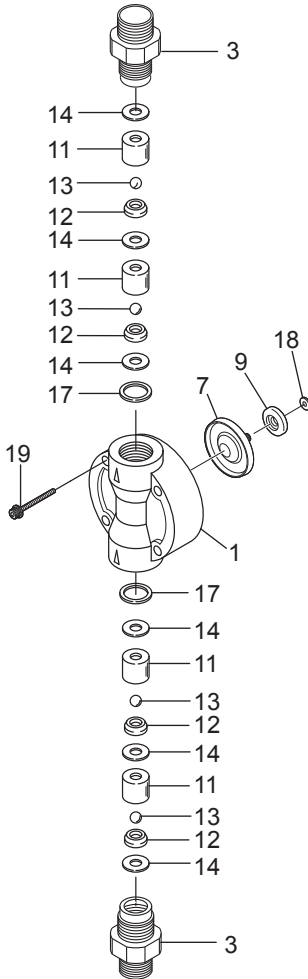

No.	Part names	# of parts
1	Pump head	1
3	Fitting	2
7	Diaphragm	1
9	Retainer	1
11	Valve guide	4
12	Valve seat	4
13	Valve	4
14	Valve gasket	6
17	Gasket	2
18	Diaphragm spacer	*
19	Hex. socket head bolt [PW•SW]	4

\*The number of diaphragm spacers varies with pump model.

■ EWN-C31PC/P6-V

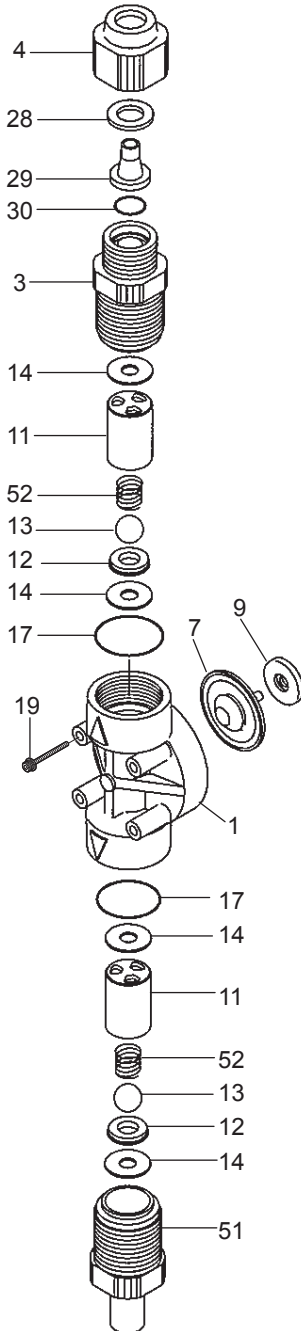

No.	Part names	# of parts
1	Pump head	1
3	Fitting	1
4	Fitting nut	1
7	Diaphragm	1
9	Retainer	1
11	Valve guide	2
12	Valve seat	2
13	Valve	2
14	Valve gasket	4
17	O ring	2
19	Hex. socket head bolt [PW•SW]	4
28	Hose stopper	1
29	Fitting spacer	1
30	O ring	1
51	Inlet	1
52	Valve spring	2

\*The number of diaphragm spacers varies with pump model.

■ EWN-□SH & SH-H

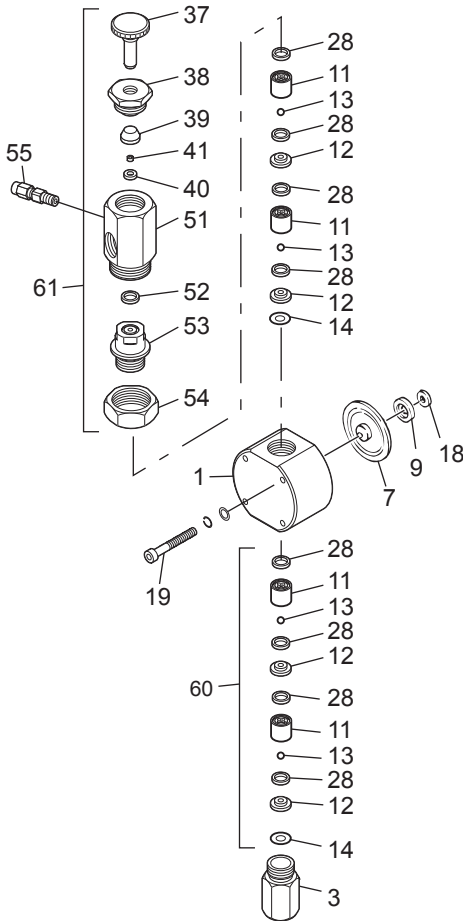

No.	Part names	# of parts
1	Pump head	1
3	Fitting	1
7	Diaphragm	1
9	Retainer	1
11	Valve guide	4
12	Valve seat	4
13	Valve	4
14	Valve gasket B	2
18	Diaphragm spacer	*
19	Hex. socket head bolt [PW•SW]	4
28	Valve gasket A	8
37	Adjusting screw	1
38	Seal nut	1
39	Seal ring	1
40	Seat	1
41	Seat ring	1
51	Air vent body A	1
52	Gasket	1
53	Air vent body B	1
54	Nut	1
55	Male connector	1

\*The number of diaphragm spacers varies with pump model.

\*For the high pressure types, a rear diaphragm sheet is placed between the parts 7 and 9.

## ■ EWN- Automatic air vent type

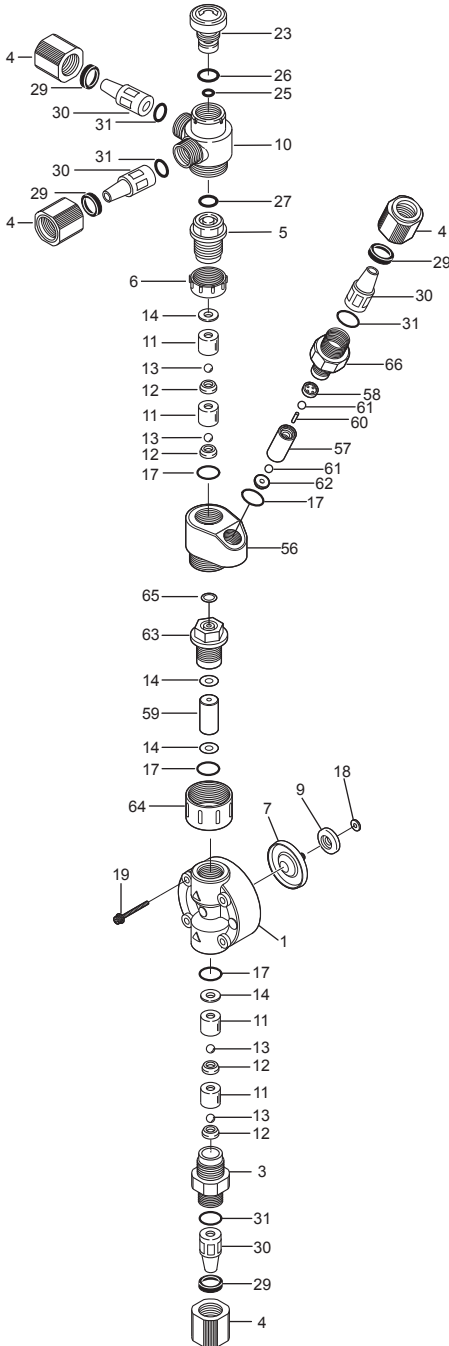

No.	Part names	# of parts
1	Pump head	1
2	Bracket	1
3	Fitting	2
4	Fitting nut	4
5	Air vent body B	1
6	Lock nut	1
7	Diaphragm	1
9	Retainer	1
10	Air vent body A	1
11	Valve guide	4
12	Valve seat	4
13	Valve	4
14	Valve gasket	4
17	O ring	4
18	Diaphragm spacer	1
19	Hex. sock. cap bolt [PW•SW]	4
22	Diaphragm seal	1
23	Adjusting screw	1
24	Name plate	1
25	O ring	1
26	O ring	1
27	O ring	1
28	Bracket spacer	1
29	Hose stopper	4
30	Hose adapter	4
31	O ring	4
56	Fitting adapter	1
57	Air vent valve guide A	1
58	Air vent valve guide B	1
59	Spacer	1
60	Separate pin	1
61	Valve	2
62	Valve seat	1
63	Air vent body B	1
64	Lock nut	1
65	O ring	1
66	Air vent fitting	1

## Specification/Outer dimension

### Specification

Specifications and apparent condition are subject to change without notice.

#### ■ Pump unit

#### VC•VH•PC•PH

Model code	Flow rate ml/min	Discharge pressure MPa	Stroke length % (mm)	Stroke rate % (spm)	Power con- sumption W	Current value A	Weight kg
EWN-B11	2.28 (38)	1.0	50-100 (0.5-1.0)	0.1-100 (1-360)	20	0.8	2.8
EWN-B16	3.9 (65)	0.7					
EWN-B21	6.0 (100)	0.4					
EWN-B31	12.0 (200)	0.2					
EWN-C16	4.8 (80)	1.0	40-100 (0.5-1.25)		24	1.2	3.7
EWN-C21	7.8 (130)	0.7					
EWN-C31	16.2 (270)	0.35					
EWN-C36	25.2 (420)	0.2					

#### FC•SH•TC

Model code	Flow rate ml/min	Discharge pressure MPa	Stroke length % (mm)	Stroke rate % (spm)	Power con- sumption W	Current value A	Weight kg
EWN-B11	2.28 (38)	1.0	50-100 (0.5-1.0)	0.1-100 (1-360)	20	0.8	2.8
EWN-B16	3.9 (65)	0.7					
EWN-B21	6.0 (100)	0.4					
EWN-B31	12.0 (200)	0.2					
EWN-C16	4.8 (80)	1.0	40-100 (0.5-1.25)		24	1.2	3.7
EWN-C21	7.8 (130)	0.7					
EWN-C31	16.2 (270)	0.35					
EWN-C36	24.6 (410)	0.2					

### VC•VH (High compression type)

Model code	Flow rate ml/min	Discharge pressure MPa	Stroke length % (mm)	Stroke rate % (spm)	Power con- sumption W	Current value A	Weight kg
EWN-B09	0.72 (12)	1.0	50-100 (0.625-1.25)	0.1-100 (1-180)	20	0.8	2.8
EWN-B11	1.38 (23)	1.0					
EWN-B16	2.40 (40)	0.7					
EWN-B21	3.78 (63)	0.4					
EWN-C16	3.24 (54)	1.0	40-100 (0.6-1.50)		24	1.2	3.7
EWN-C21	4.68 (78)	0.7					

### PC•PH•SH (High pressure type)

Model code	Flow rate ml/min	Discharge pressure MPa	Stroke length % (mm)	Stroke rate % (spm)	Power con- sumption W	Current value A	Weight kg
EWN-B11	1.50 (25)	1.7	50-100 (0.5-1.0)	0.1-100 (1-240)	20	0.8	2.8 (SH3.6)
EWN-C16	2.4 (40)	1.7	40-100 (0.5-1.25)		24	1.2	3.7 (SH4.5)

### PC•P6 (High viscosity type)

Model code	Flow rate ml/min	Discharge pressure MPa	Stroke length % (mm)	Stroke rate % (spm)	Power con- sumption W	Current value A	Weight kg
EWN-C31	7.44 (124)	0.35	40-100 (0.5-1.25)	0.1-100 (1-240)	24	1.2	3.7

### Automatic air vent type

Model code	Flow rate ml/min	Discharge pressure MPa	Stroke length % (mm)	Stroke rate % (spm)	Power con- sumption W	Current value A	Weight kg
EWN-B11	1.8 (30)	1.0	50-100 (0.5-1.0)	0.1-100 (1-360)	20	0.8	2.9
EWN-B16	3.3 (55)	0.7					
EWN-C16	3.9 (65)	1.0	40-100 (0.5-1.25)		24	1.2	3.8
EWN-C21	6.6 (110)	0.7					

\*These specifications are based on pumping ambient clean water at rated voltage.

\*Flow rate is collected at the maximum discharge pressure, 100% stroke length and 100% stroke rate. The flow rate increases as a discharge pressure decreases.

\*Allowable room temperature: 0-40°C

\*Allowable liquid temperature: 0-40°C (0-60°C for the PC•PH•FC)

\*Allowable voltage deviation: ±10% of the rated voltage

\*For the PC/P6-V types, their flow rate is collected with clean water and is not warranted for viscous liquid. The flow rate may increase or decrease depending on liquid characteristics.

#### ■ Power cable

Conduction section area	0.75 [mm <sup>2</sup> ] Triplex cable(L/N/PE)	Standard	H03VV-F
Length	2000 [mm]	Terminal treatment	European plug

#### ■ Pump colour

Blue	Munsell colour system 7.5PB 3/8
Red	Munsell colour system 5R 3/10

# Outer dimensions

## ■ EWN-[B11•B16•B21] [VC•VH•PC•PH]

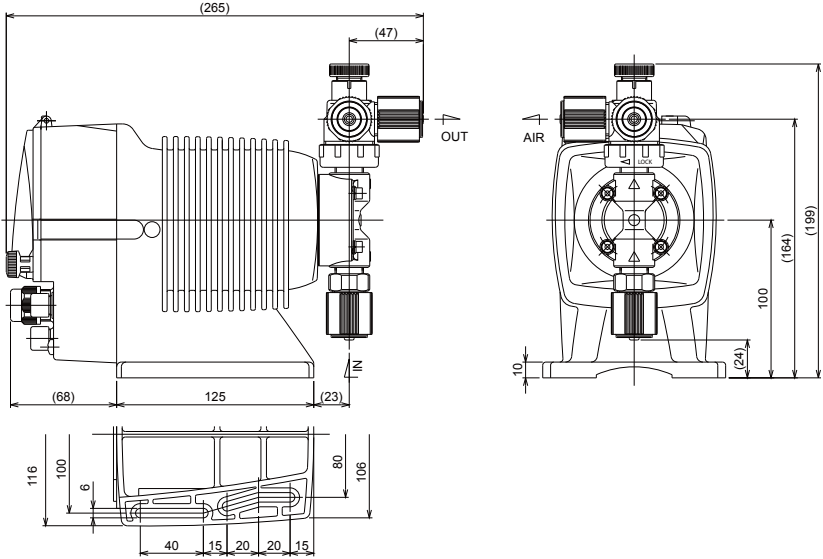

## ■ EWN-B31[VC•VH•PC•PH]

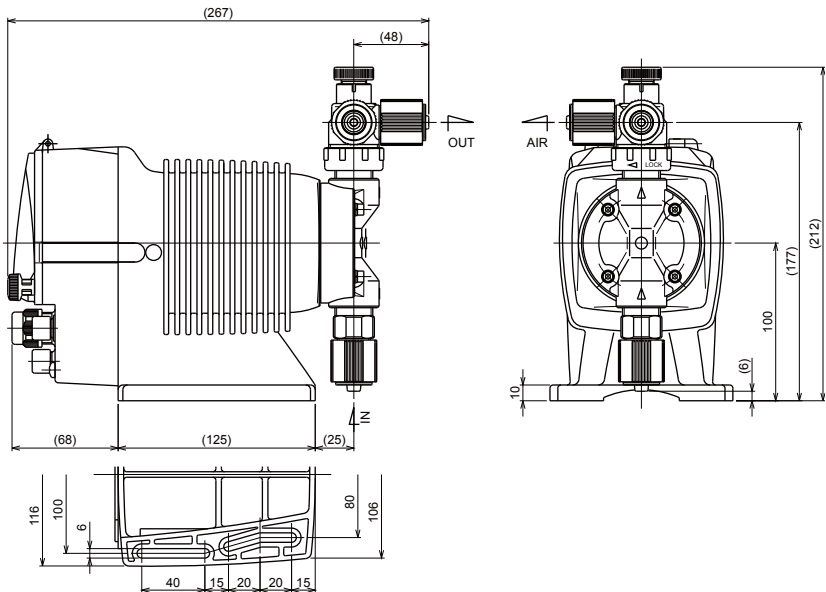

■ EWN-[C16•C21] [VC•VH•PC•PH]

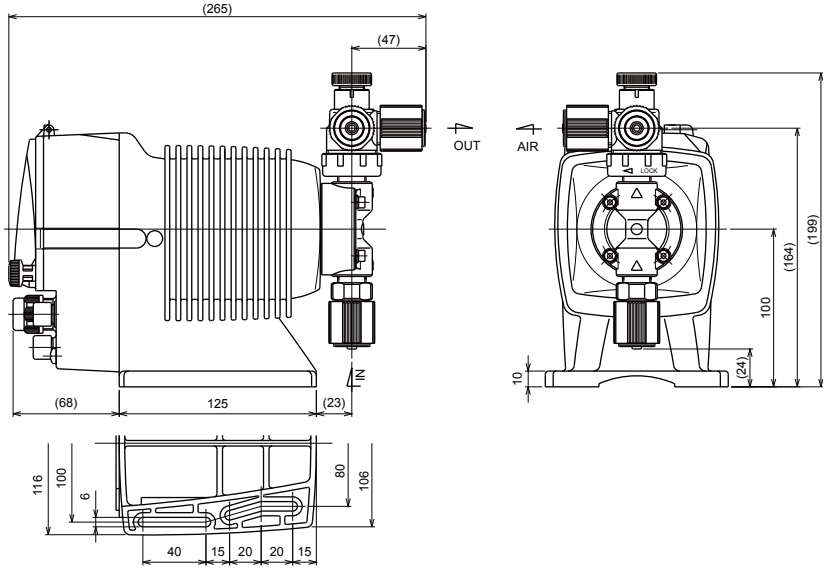

■ EWN-C31 [VC•VH•PC•PH]

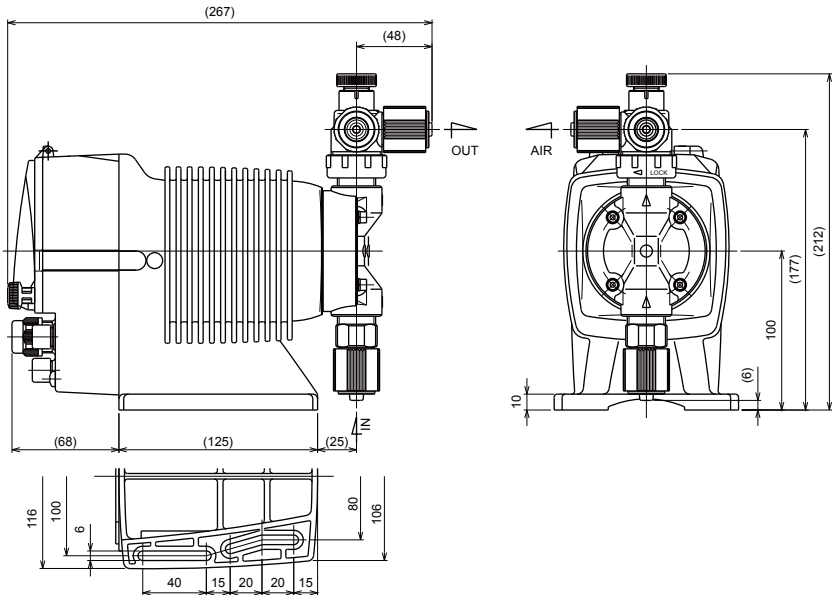



■ EWN-B31FC

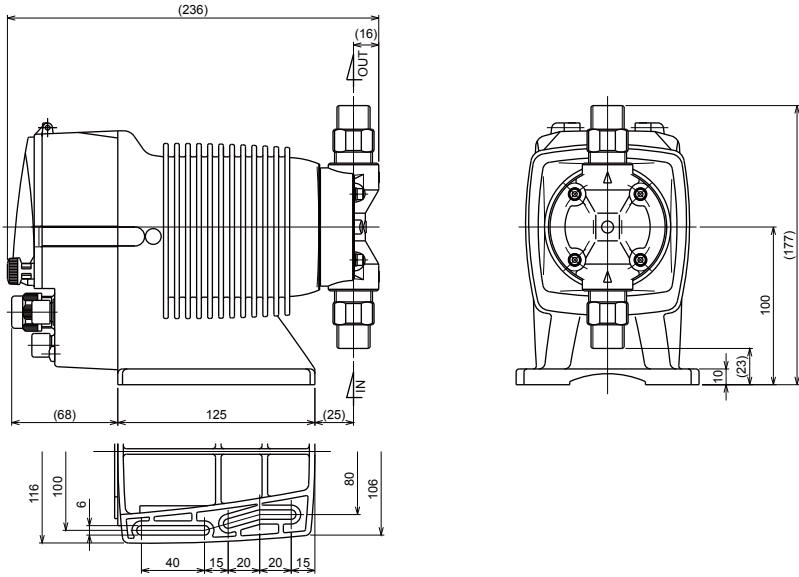

■ EWN-[C16-C21]FC

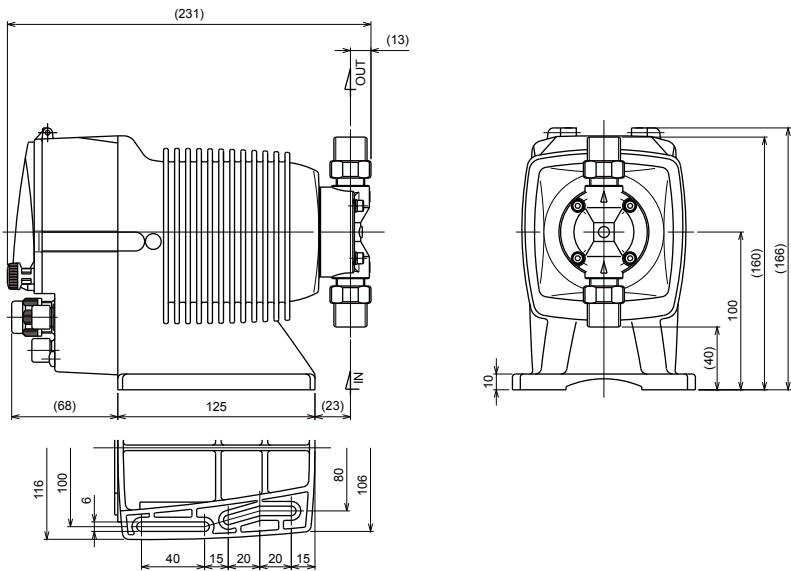

■ EWN-C31FC

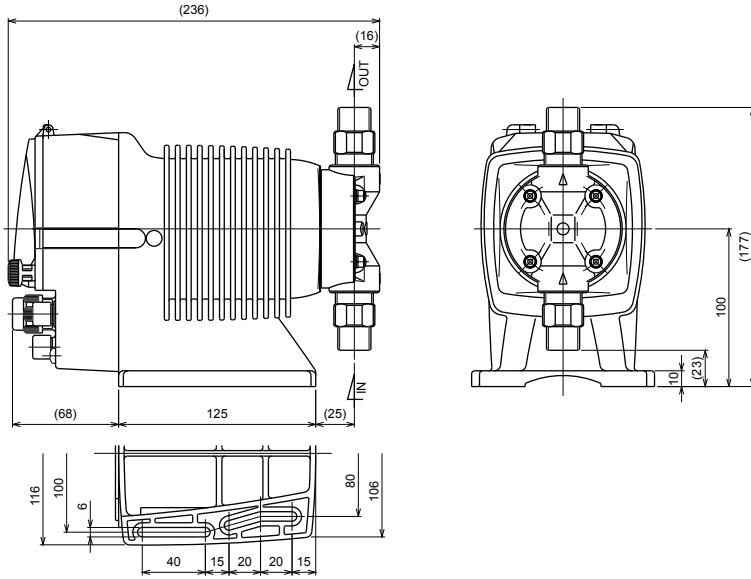

■ EWN-C36FC

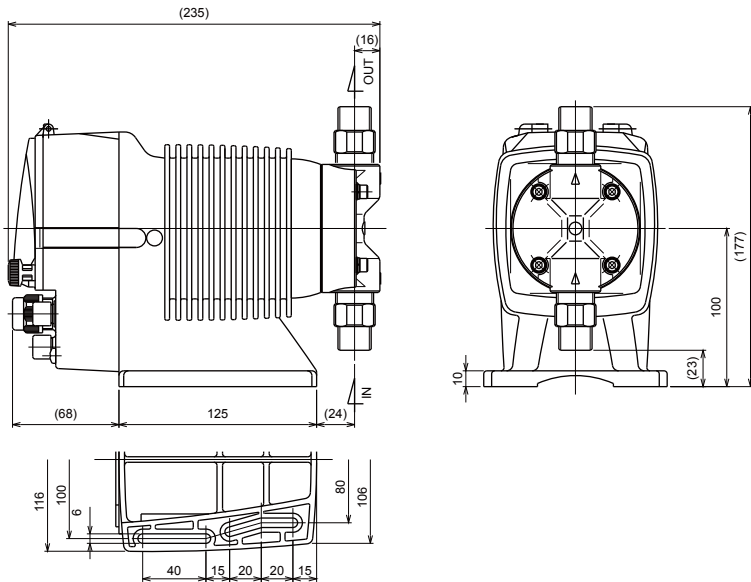



■ EWN-[C16-C21]TC

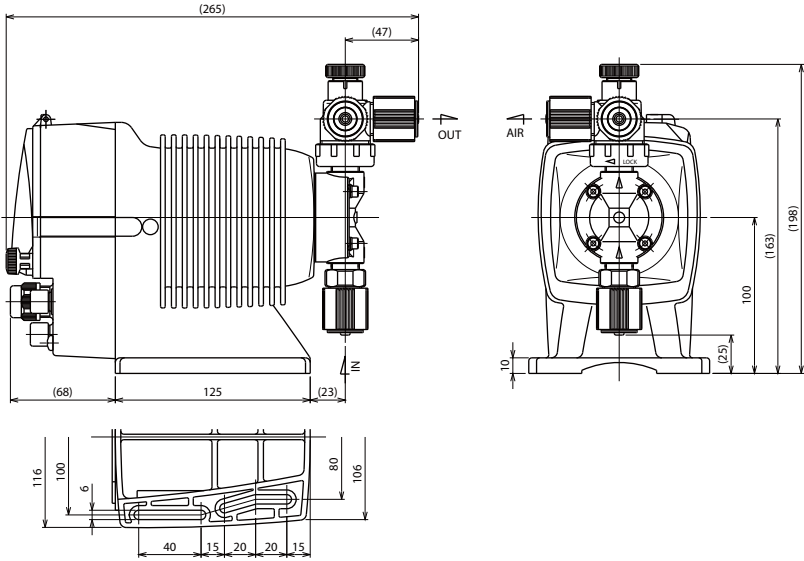

■ EWN-C31TC

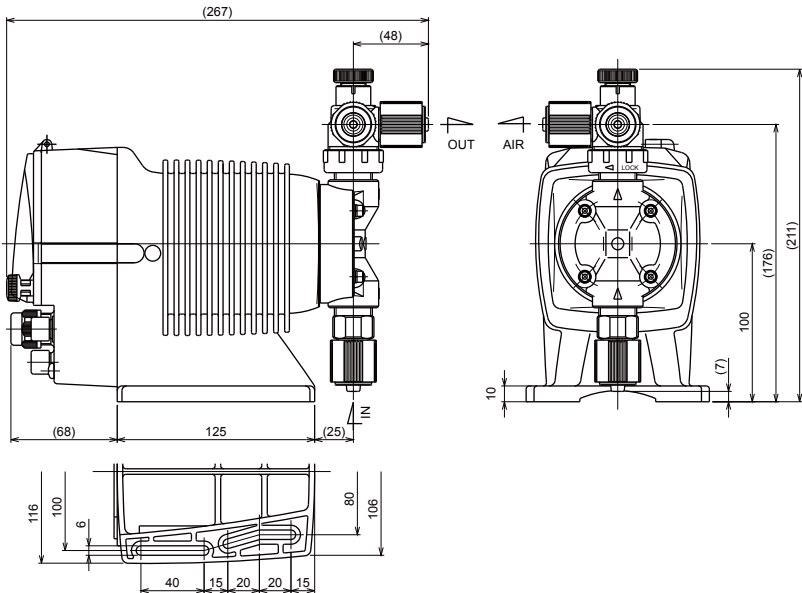

■ EWN-C36TC

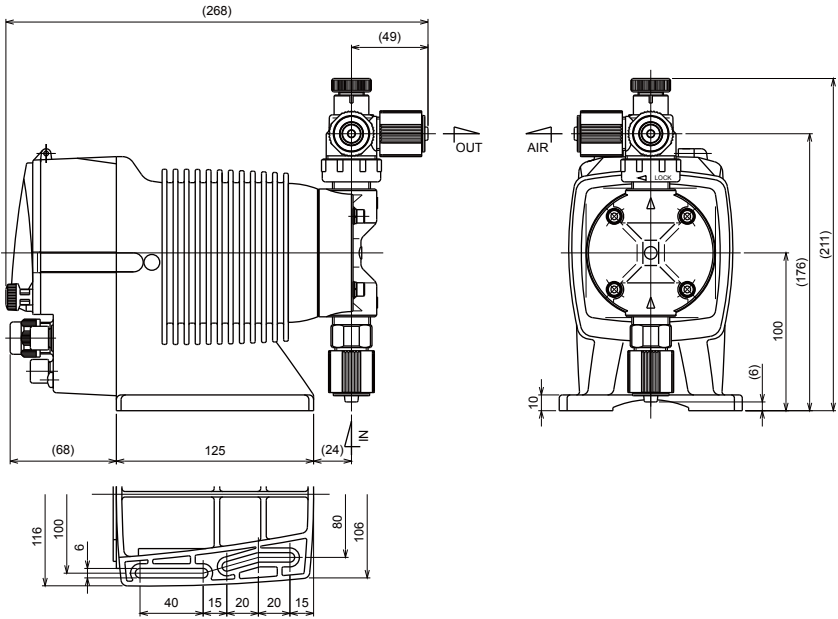

■ EWN-[B11•B16•B21]SH

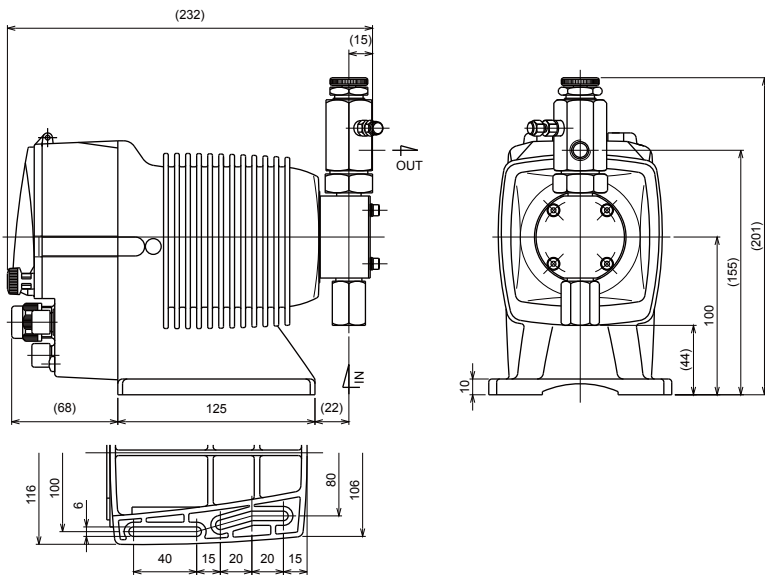

■ EWN-B31SH

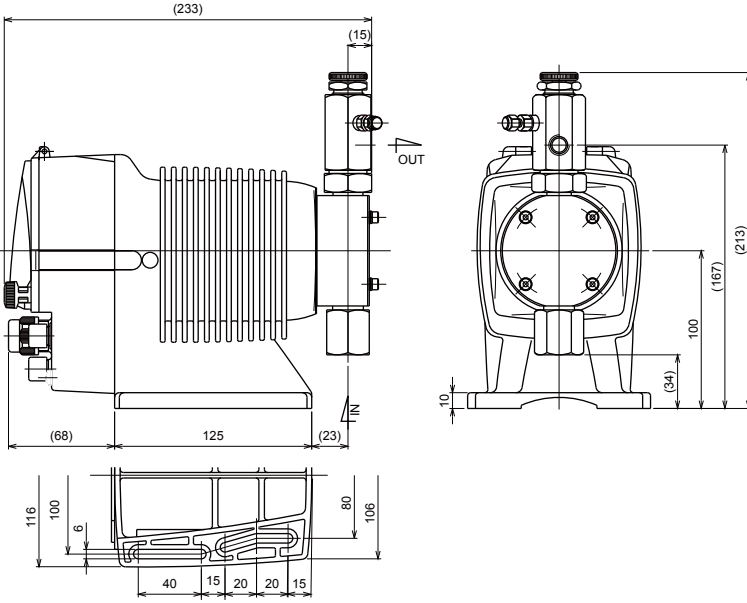

■ EWN-[C16-C21]SH

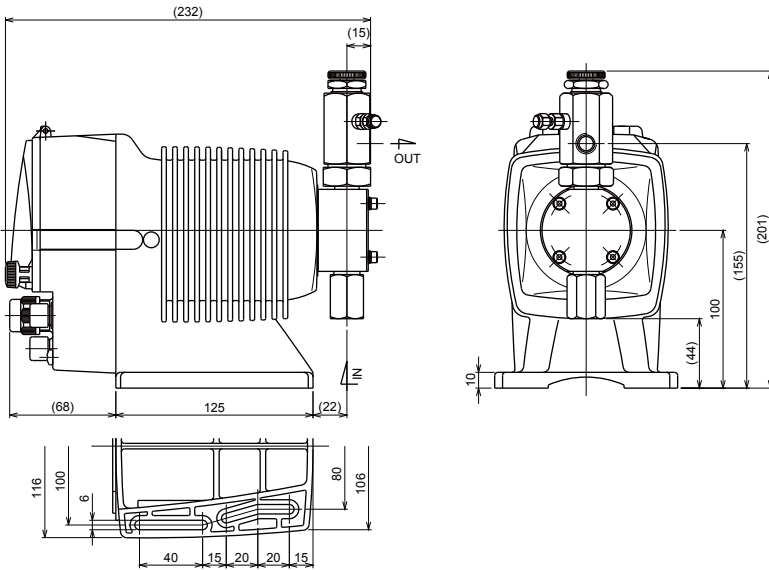

■ EWN-C31SH

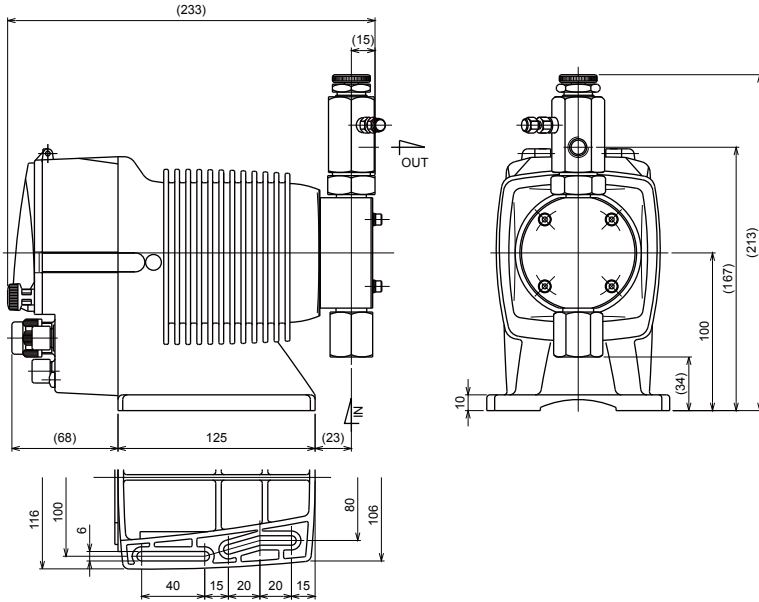

■ EWN-C36SH

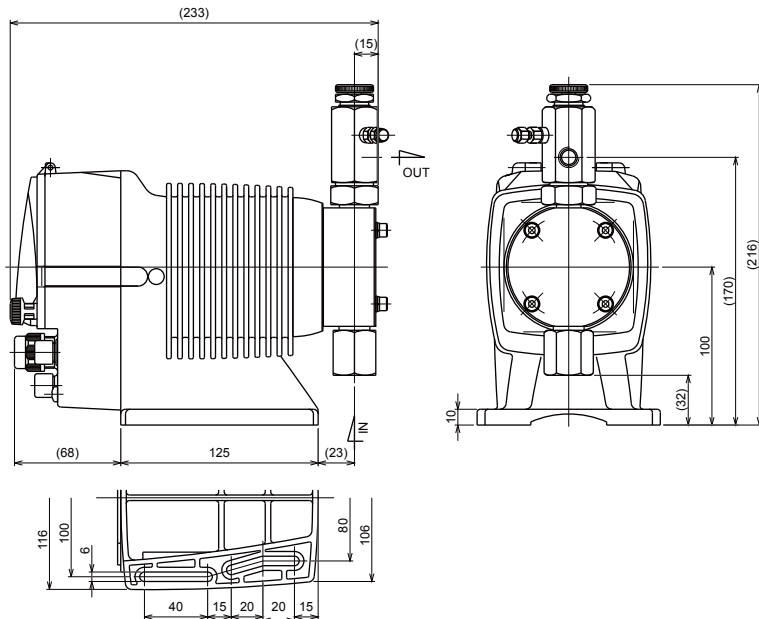

■ EWN-[B09•B11•B16•B21] [VC•VH] (High compression type)

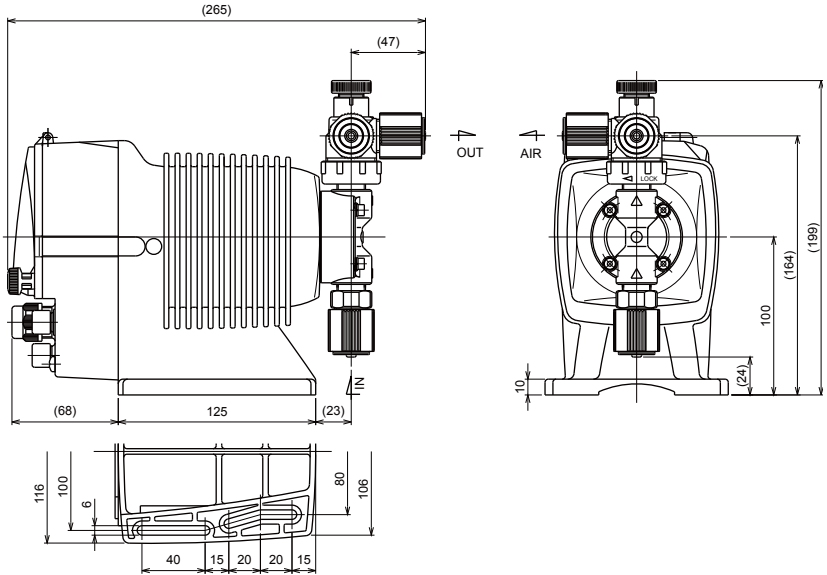

■ EWN-[C16•C21] [VC•VH] (High compression type)

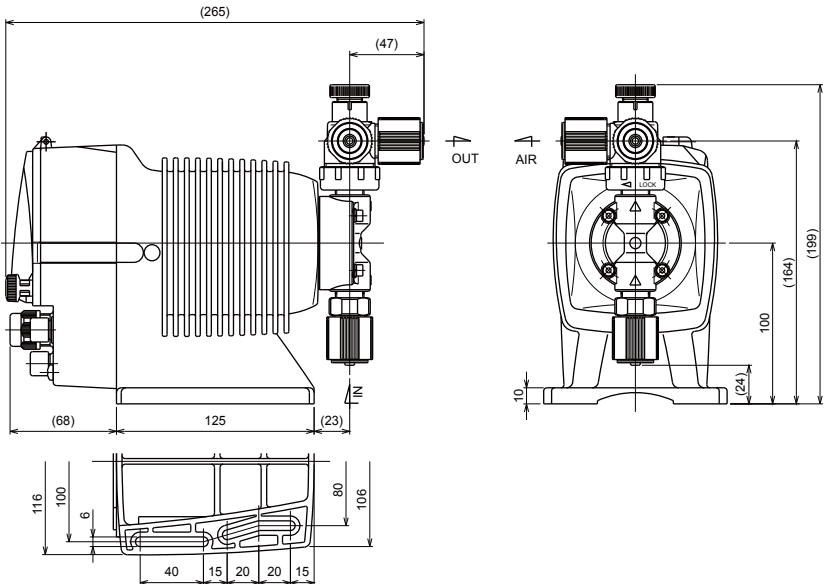

■ EWN-B11 [PC·PH] (High pressure type)

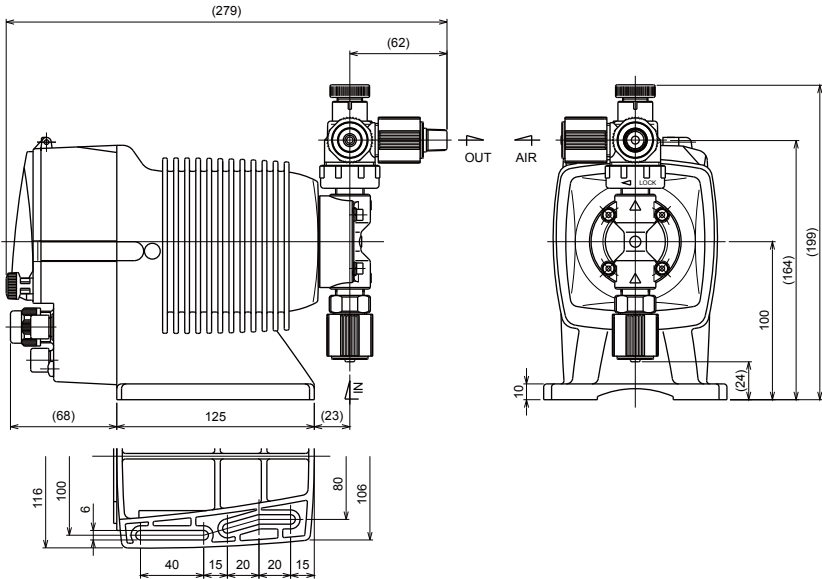

■ EWN-C16 [PC·PH] (High pressure type)

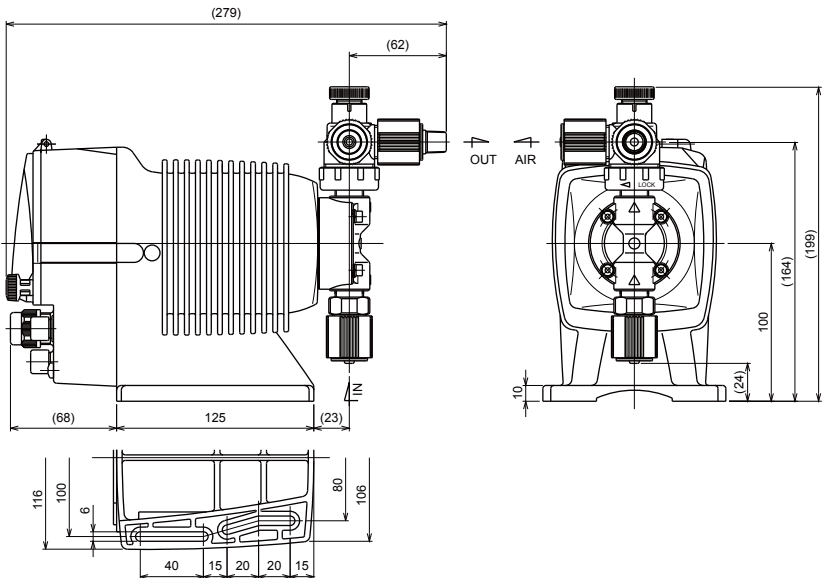

■ EWN-B11SH (High pressure type)

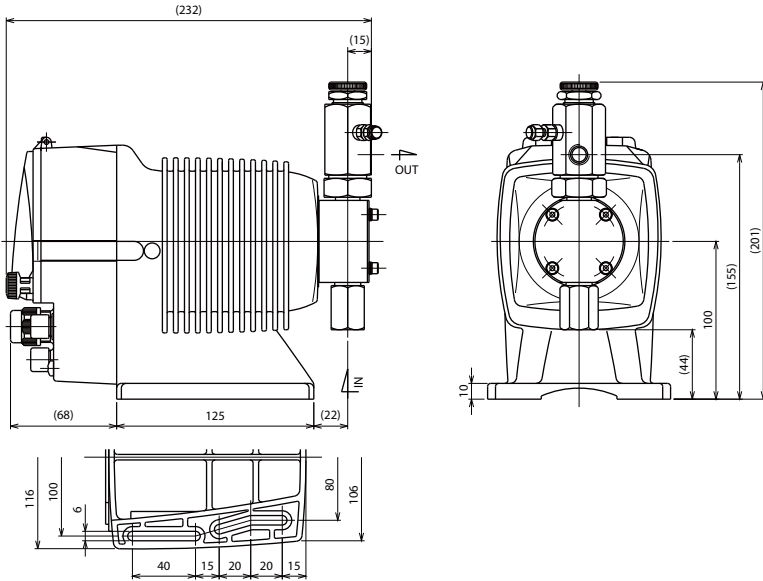

■ EWN-C16SH (High pressure type)

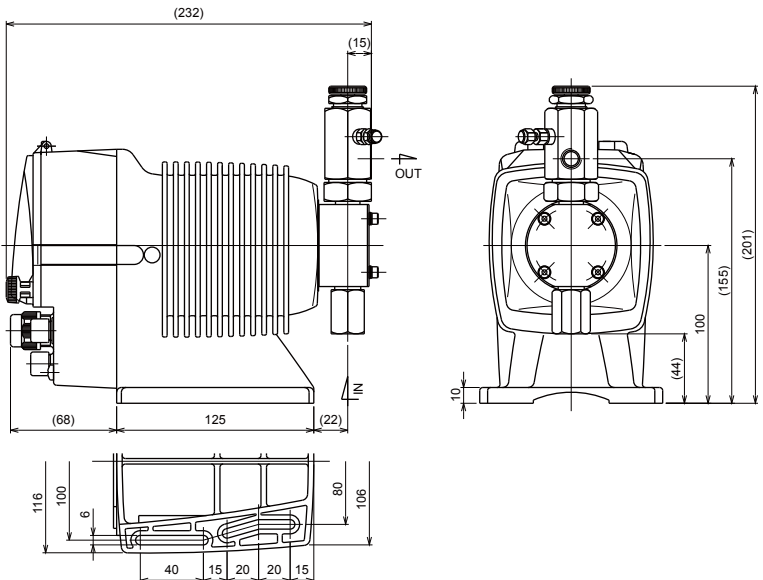

■ EWN-C31 [PC·P6] (High viscosity type)

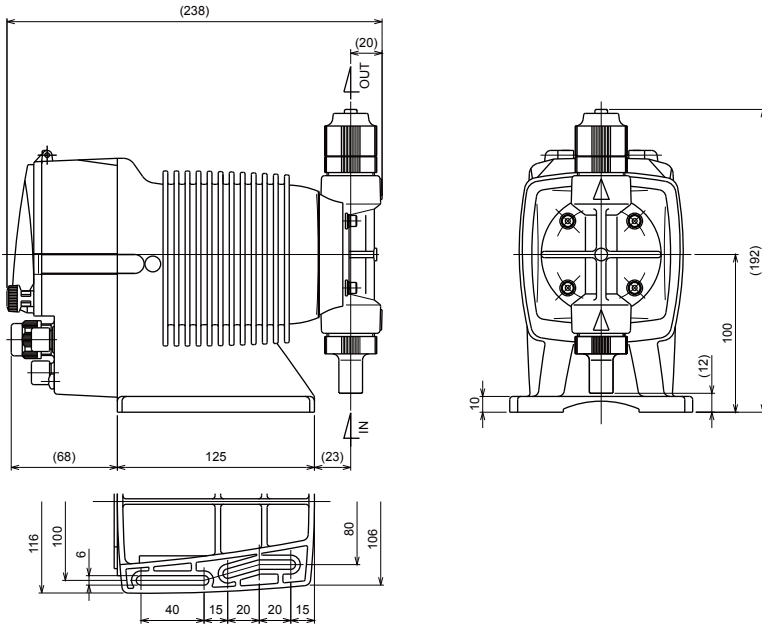

■ EWN- [B11·B16] (Automatic air vent type)

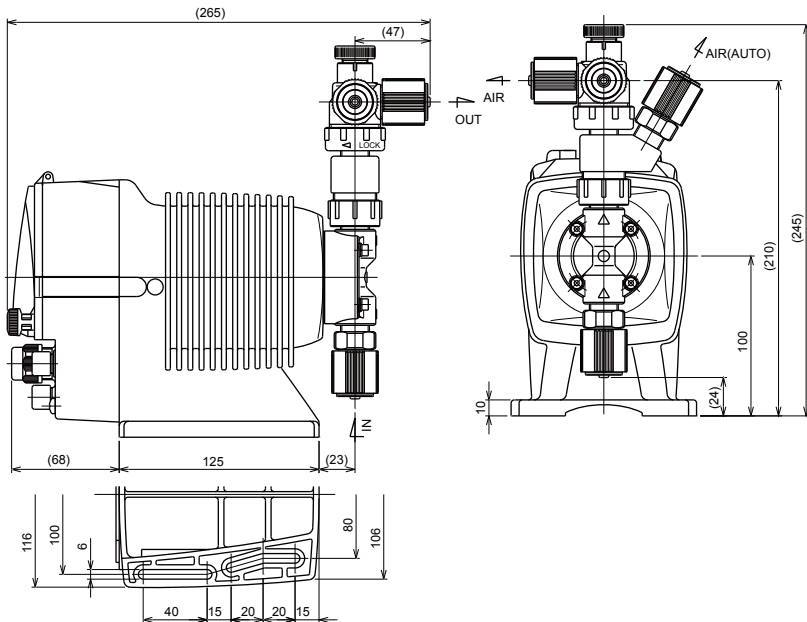

■ EWN- [C16•C21] (Automatic air vent type)

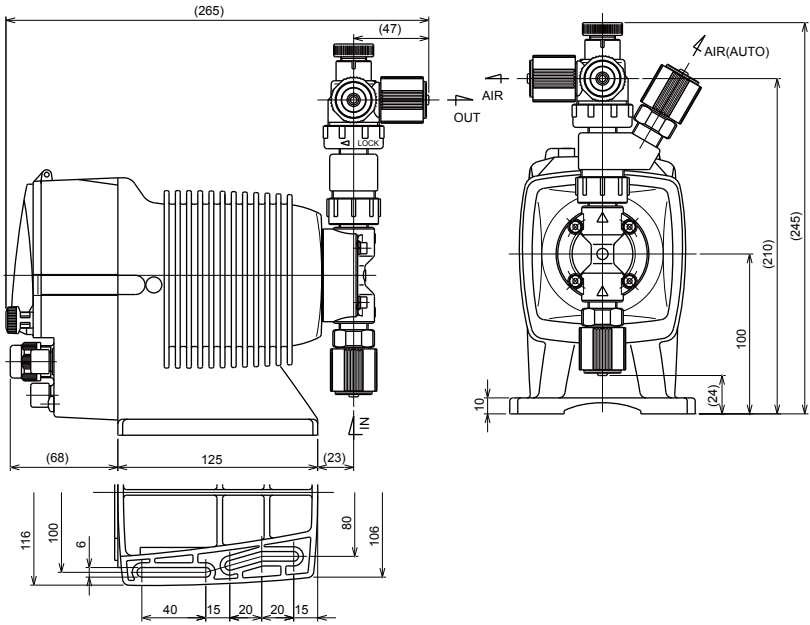



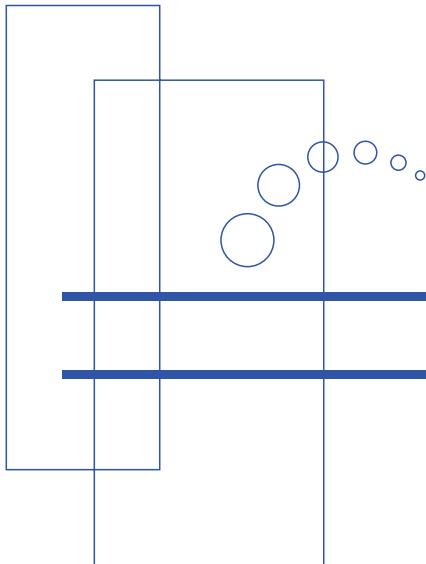

<http://www.iwakipumps.jp>

( )Country codes

**IWAKI CO.,LTD.** 6-6 Kanda-Sudacho 2-chome Chiyoda-ku Tokyo 101-8558 Japan  
 TEL:(81)3 3254 2935 FAX:3 3252 8892(<http://www.iwakipumps.jp>)

Australia	IWAKI Pumps Australia Pty. Ltd.	TEL: (61)2 9899 2411	FAX: 2 9899 2421	Italy	IWAKI Italia S.R.L.	TEL: (39)02 990 9331	FAX: 02 990 42888
Austria	IWAKI (Austria) GmbH	TEL: (43)2 236 33469	FAX: 2 236 33469	Korea	IWAKI Korea Co.,Ltd.	TEL: (82)2 2630 4800	FAX: 2 2630 4801
Belgium	IWAKI Belgium n.v.	TEL: (32)1367 0200	FAX: 1367 2030	Malaysia	IWAKIm Sdn. Bhd.	TEL: (60)3 7803 8807	FAX: 3 7803 4800
China	IWAKI Pumps (Shanghai) Co., Ltd.	TEL: (86)21 6272 7502	FAX: 21 6272 6929	Norway	IWAKI Norge AS	TEL: (47)66 81 16 60	FAX: 66 81 16 61
China	IWAKI Pumps (Guandong) Co., Ltd.	TEL: (86)750 3866 228	FAX: 750 3866 278	Singapore	IWAKI Singapore Pte. Ltd.	TEL: (65)6316 2028	FAX: 6316 3221
China	GFTZIWAKI Engineering & Trading (Guangzhou)	TEL: (86)20 8435 0603	FAX: 20 8435 9181	Spain	IWAKI Iberica Pumps, S.A.	TEL: (34)943 630030	FAX: 943 628799
China	GFTZIWAKI Engineering & Trading (Beijing)	TEL: (86)10 6442 7713	FAX: 10 6442 7712	Sweden	IWAKI Sverige AB	TEL: (46)8 511 72900	FAX: 8 511 72922
Denmark	IWAKI Nordic A/S	TEL: (45)48 24 2345	FAX: 48 24 2346	Switzerland	IWAKI (Schweiz) AG	TEL: (41)26 674 9300	FAX: 26 674 9302
Finland	IWAKI Suomi Oy	TEL: (358)9 2745 810	FAX: 9 2742 715	Taiwan	IWAKI Pumps Taiwan Co., Ltd.	TEL: (886)2 8227 6900	FAX: 2 8227 6818
France	IWAKI France S.A.	TEL: (33)1 69 63 33 70	FAX: 1 64 49 92 73	Taiwan	IWAKI Pumps Taiwan (Hsin-chu) Co., Ltd.	TEL: (886)3 573 5797	FAX: (886)3 573 5798
Germany	IWAKI EUROPE GmbH	TEL: (49)2154 92540	FAX: 2154 925448	Thailand	IWAKI (Thailand) Co.,Ltd.	TEL: (66)2 322 2471	FAX: 2 322 2477
Holland	IWAKI Holland B.V.	TEL: (31)547 293 160	FAX: 547 292 332	U.K.	IWAKI Pumps (UK) LTD.	TEL: (44)1743 231363	FAX: 1743 366507
Hong Kong	IWAKI Pumps Co., Ltd.	TEL: (852)2 607 1168	FAX: 2 607 1000	U.S.A.	IWAKI AMERICA Inc	TEL: (1)508 429 1440	FAX: 508 429 1386
Indonesia	IWAKI Singapore (Indonesia Branch)	TEL: (62)21 690 6606	FAX: 21 690 6612	Vietnam	IWAKI Pumps Vietnam Co.,Ltd.	TEL: (84)613 933456	FAX: 613 933399